



Operating Guide

VLT[®] Refrigeration Drive FC 103

75–400 kW



Contents

1 Introduction	3
1.1 Purpose of the Manual	3
1.2 Additional Resources	3
1.3 Document and Software Version	3
1.4 Product Overview	3
1.5 Approvals and Certifications	6
1.6 Disposal	6
2 Safety	7
2.1 Safety Symbols	7
2.2 Qualified Personnel	7
2.3 Safety Precautions	7
3 Mechanical Installation	9
3.1 Unpacking	9
3.2 Installation Environments	9
3.3 Mounting	9
4 Electrical Installation	11
4.1 Safety Instructions	11
4.2 EMC-compliant Installation	11
4.3 Grounding	11
4.4 Wiring Schematic	13
4.5 Access	14
4.6 Motor Connection	14
4.7 AC Mains Connection	31
4.8 Control Wiring	32
4.8.1 Control Terminal Types	32
4.8.2 Wiring to Control Terminals	33
4.8.3 Enabling Motor Operation (Terminal 27)	34
4.8.4 Voltage/Current Input Selection (Switches)	34
4.8.5 Safe Torque Off (STO)	34
4.9 Installation Check List	36
5 Commissioning	37
5.1 Safety Instructions	37
5.2 Applying Power	37
5.3 Local Control Panel Operation	37
5.4 Basic Programming	40
5.4.1 Commissioning with SmartStart	40

5.4.2 Commissioning via [Main Menu]	40
5.5 Checking Motor Rotation	41
5.6 Local-control Test	42
5.7 System Start-up	42
6 Application Set-up Examples	43
6.1 Introduction	43
6.2 Application Examples	43
7 Maintenance, Diagnostics, and Troubleshooting	48
7.1 Introduction	48
7.2 Maintenance and Service	48
7.3 Heat Sink Access Panel	48
7.3.1 Removing the Heat Sink Access Panel	48
7.4 Status Messages	49
7.5 Warning and Alarm Types	51
7.6 List of Warnings and Alarms	52
7.7 Troubleshooting	60
8 Specifications	62
8.1 Electrical Data	62
8.1.1 Mains Supply 3x380–500 V AC	62
8.1.2 Mains Supply 3x525–690 V AC	64
8.2 Mains Supply	65
8.3 Motor Output and Motor Data	65
8.4 Ambient Conditions	65
8.5 Cable Specifications	66
8.6 Control Input/Output and Control Data	66
8.7 Fuses	69
8.8 Connection Tightening Torques	72
8.9 Power Ratings, Weight, and Dimensions	72
9 Appendix	74
9.1 Symbols, Abbreviations, and Conventions	74
9.2 Parameter Menu Structure	74
Index	79

1 Introduction

1.1 Purpose of the Manual

This operating guide provides information for safe installation and commissioning of the frequency converter.

The operating guide is intended for use by qualified personnel.

Read and follow the instructions to use the frequency converter safely and professionally, and pay particular attention to the safety instructions and general warnings. Always keep this operating guide available with the frequency converter.

VLT® is a registered trademark.

1.2 Additional Resources

Other resources are available to understand advanced frequency converter functions and programming.

- The *VLT® Refrigeration Drive FC 103 Programming Guide* provides greater detail on working with parameters and many application examples.
- The *VLT® Refrigeration Drive FC 103 Design Guide* provides detailed information about capabilities and functionality to design motor control systems.
- Instructions for operation with optional equipment.

Supplementary publications and manuals are available from Danfoss. See drives.danfoss.com/knowledge-center/technical-documentation/ for listings.

1.3 Document and Software Version

This manual is regularly reviewed and updated. All suggestions for improvement are welcome. *Table 1.1* shows the document version and the corresponding software version.

Edition	Remarks	Software version
MG16F2	Software update and editorial update	1.5x

Table 1.1 Document and Software Version

1.4 Product Overview

1.4.1 Intended Use

The frequency converter is an electronic motor controller intended for:

- Regulation of motor speed in response to system feedback or to remote commands from external controllers. A power drive system consists of the frequency converter, the motor, and the equipment driven by the motor.
- System and motor status surveillance.

The frequency converter can also be used for motor overload protection.

Depending on the configuration, the frequency converter can be used in standalone applications or form part of a larger appliance or installation.

The frequency converter is allowed for use in residential, industrial, and commercial environments in accordance with local laws and standards.

NOTICE

In a residential environment, this product can cause radio interference, in which case supplementary mitigation measures can be required.

Foreseeable misuse

Do not use the frequency converter in applications which are non-compliant with specified operating conditions and environments. Ensure compliance with the conditions specified in *chapter 8 Specifications*.

1.4.2 Interior Views

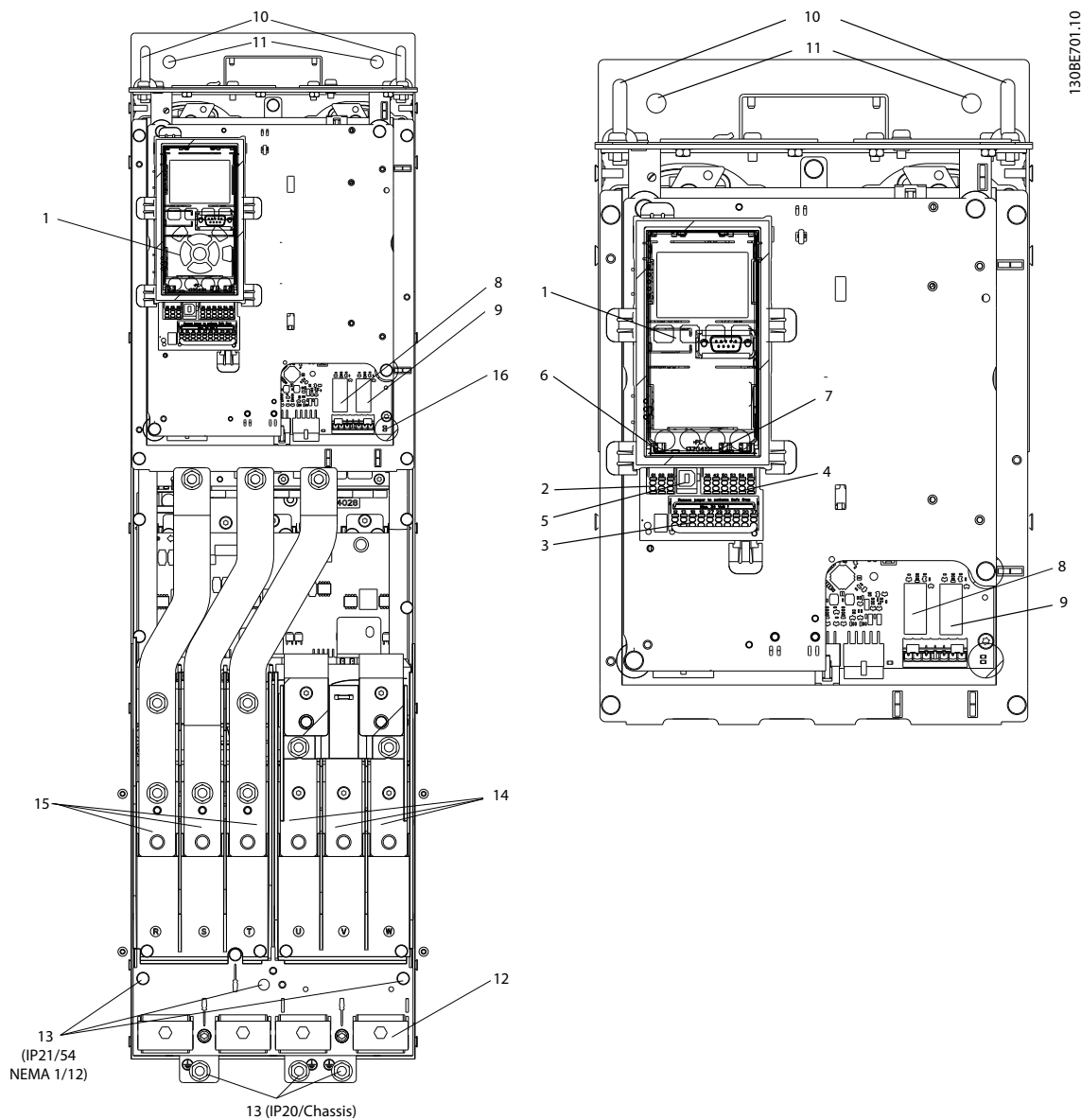

1	LCP (local control panel)	9	Relay 2 (04, 05, 06)
2	RS485 fieldbus connector	10	Lifting ring
3	Digital I/O and 24 V power supply	11	Mounting holes
4	Analog I/O connector	12	Cable clamp (PE)
5	USB connector	13	Ground
6	Fieldbus terminal switch	14	Motor output terminals 96 (U), 97 (V), 98 (W)
7	Analog switches (A53, A54)	15	Mains input terminals 91 (L1), 92 (L2), 93 (L3)
8	Relay 1 (01, 02, 03)	16	TB5 (IP21/54 only). Terminal block for anti-condensation heater

Illustration 1.1 D1 Interior Components (left); Close-up View: LCP and Control Functions (right)

NOTICE

For location of TB6 (terminal block for contactor), see chapter 4.6 Motor Connection.

1.4.3 Extended Options Cabinets

If a frequency converter is ordered with 1 of the following options, it is supplied with an options cabinet that increases the height.

- Brake chopper.
- Mains disconnect.
- Contactor.
- Mains disconnect with contactor.
- Circuit breaker.
- Oversized wiring cabinet.
- Regeneration terminals.
- Load sharing terminals.

Illustration 1.2 shows an example of a frequency converter with an options cabinet. Table 1.2 lists the variants for the frequency converters that include input options.

Options unit designations	Extension cabinets	Possible options
D5h	D1h enclosure with short extension.	<ul style="list-style-type: none"> • Brake. • Disconnect.
D6h	D1h enclosure with tall extension.	<ul style="list-style-type: none"> • Contactor. • Contactor with disconnect. • Circuit breaker.
D7h	D2h enclosure with short extension.	<ul style="list-style-type: none"> • Brake. • Disconnect.
D8h	D2h enclosure with tall extension.	<ul style="list-style-type: none"> • Contactor. • Contactor with disconnect. • Circuit breaker.

Table 1.2 Overview of Extended Options

The D7h and D8h frequency converters (D2h plus options cabinet) include a 200 mm (7.9 in) pedestal for floor mounting.

There is a safety latch on the front cover of the options cabinet. If the frequency converter is supplied with a mains disconnect or circuit breaker, the safety latch prevents the cabinet door from being opened while the frequency converter is energized. Before opening the door of the frequency converter, open the disconnect or circuit breaker (to de-energize the frequency converter) and remove the cover of the options cabinet.

For frequency converters purchased with a disconnect, contactor or circuit breaker, the nameplate label includes a type code for a replacement that does not include the option. If there is a problem with the frequency converter, it is replaced independently of the options.

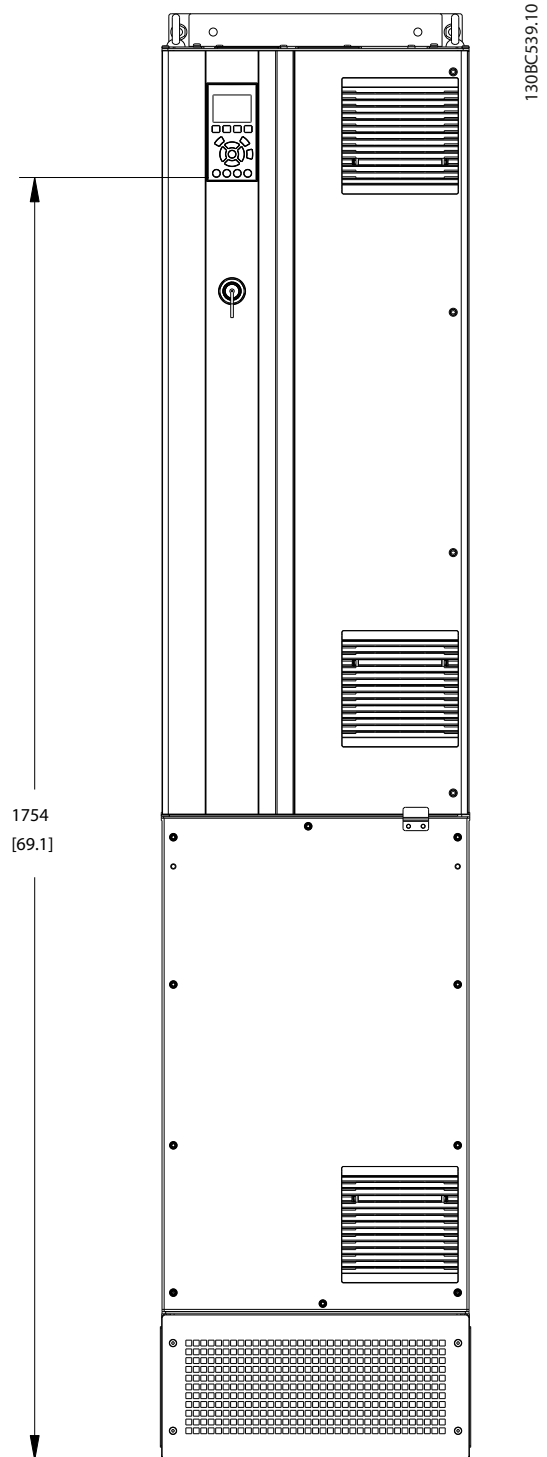
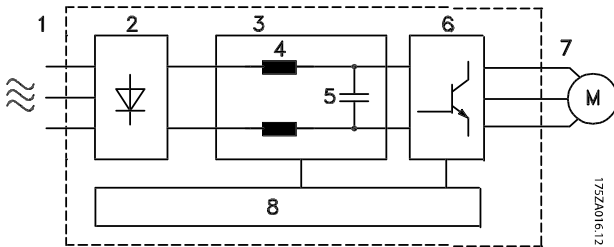

Illustration 1.2 D7h Enclosure

1.4.4 Block Diagram of the Frequency Converter

Illustration 1.3 is a block diagram of the internal components of the frequency converter.



Area	Title	Functions
1	Mains input	<ul style="list-style-type: none"> 3-phase AC mains supply to the frequency converter.
2	Rectifier	<ul style="list-style-type: none"> The rectifier bridge converts the AC input to DC current to supply inverter power.
3	DC bus	<ul style="list-style-type: none"> Intermediate DC-bus circuit handles the DC current.
4	DC reactors	<ul style="list-style-type: none"> Filter the intermediate DC circuit voltage. Provide mains transient protection. Reduce RMS current. Raise the power factor reflected back to the line. Reduce harmonics on the AC input.
5	Capacitor bank	<ul style="list-style-type: none"> Stores the DC power. Provides ride-through protection for short power losses.
6	Inverter	<ul style="list-style-type: none"> Converts the DC into a controlled PWM AC waveform for a controlled variable output to the motor.
7	Output to motor	<ul style="list-style-type: none"> Regulated 3-phase output power to the motor.

Area	Title	Functions
8	Control circuitry	<ul style="list-style-type: none"> Input power, internal processing, output, and motor current are monitored to provide efficient operation and control. User interface and external commands are monitored and performed. Status output and control can be provided.

Illustration 1.3 Block Diagram of Frequency Converter

1.4.5 Enclosure Sizes and Power Ratings

For enclosure sizes and power ratings of the frequency converters, refer to *chapter 8.9 Power Ratings, Weight, and Dimensions*.

1.5 Approvals and Certifications



Table 1.3 Approvals and Certifications

More approvals and certifications are available. Contact the local Danfoss office or partner.

NOTICE

Frequency converters of enclosure size T7 (525–690 V) are not UL listed.

The frequency converter complies with UL 508C thermal memory retention requirements. For more information, refer to the section *Motor Thermal Protection* in the product-specific *design guide*.

1.6 Disposal

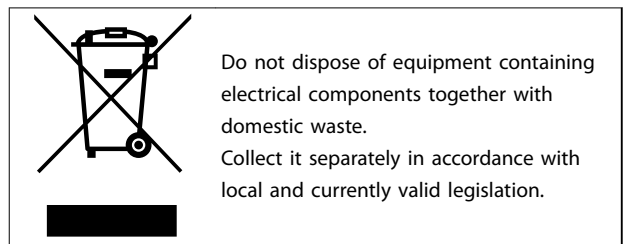

2 Safety

2.1 Safety Symbols

The following symbols are used in this guide:

⚠ WARNING

Indicates a potentially hazardous situation that could result in death or serious injury.

⚠ CAUTION

Indicates a potentially hazardous situation that could result in minor or moderate injury. It can also be used to alert against unsafe practices.

NOTICE

Indicates important information, including situations that can result in damage to equipment or property.

2.2 Qualified Personnel

Correct and reliable transport, storage, installation, operation, and maintenance are required for the trouble-free and safe operation of the frequency converter. Only qualified personnel are allowed to install and operate this equipment.

Qualified personnel are defined as trained staff, who are authorized to install, commission, and maintain equipment, systems, and circuits in accordance with pertinent laws and regulations. Also, the qualified personnel must be familiar with the instructions and safety measures described in this manual.

2.3 Safety Precautions

⚠ WARNING

HIGH VOLTAGE

Frequency converters contain high voltage when connected to AC mains input, DC supply, or load sharing. Failure to perform installation, start-up, and maintenance by qualified personnel can result in death or serious injury.

- Only qualified personnel must perform installation, start-up, and maintenance.

⚠ WARNING

UNINTENDED START

When the frequency converter is connected to AC mains, DC supply, or load sharing, the motor may start at any time. Unintended start during programming, service, or repair work can result in death, serious injury, or property damage. The motor can start via an external switch, a fieldbus command, an input reference signal from the LCP, or after a cleared fault condition.

To prevent unintended motor start:

- Disconnect the frequency converter from the mains.
- Press [Off/Reset] on the LCP before programming parameters.
- Completely wire and assemble the frequency converter, motor, and any driven equipment before connecting the frequency converter to AC mains, DC supply, or load sharing.

⚠ WARNING

DISCHARGE TIME

The frequency converter contains DC-link capacitors, which can remain charged even when the frequency converter is not powered. High voltage can be present even when the warning LED indicator lights are off. Failure to wait the specified time after power has been removed before performing service or repair work can result in death or serious injury.

- Stop the motor.
- Disconnect AC mains and remote DC-link power supplies, including battery back-ups, UPS, and DC-link connections to other frequency converters.
- Disconnect or lock PM motor.
- Wait for the capacitors to discharge fully. The minimum waiting time is 20 minutes.
- Before performing any service or repair work, use an appropriate voltage measuring device to make sure that the capacitors are fully discharged.

⚠ WARNING**LEAKAGE CURRENT HAZARD**

Leakage currents exceed 3.5 mA. Failure to ground the frequency converter properly can result in death or serious injury.

- Ensure the correct grounding of the equipment by a certified electrical installer.

⚠ WARNING**EQUIPMENT HAZARD**

Contact with rotating shafts and electrical equipment can result in death or serious injury.

- Ensure that only trained and qualified personnel perform installation, start-up, and maintenance.
- Ensure that electrical work conforms to national and local electrical codes.
- Follow the procedures in this guide.

⚠ WARNING**UNINTENDED MOTOR ROTATION
WINDMILLING**

Unintended rotation of permanent magnet motors creates voltage and can charge the unit, resulting in death, serious injury, or equipment damage.

- Ensure that permanent magnet motors are blocked to prevent unintended rotation.

⚠ CAUTION**INTERNAL FAILURE HAZARD**

An internal failure in the frequency converter can result in serious injury when the frequency converter is not properly closed.

- Ensure that all safety covers are in place and securely fastened before applying power.

3 Mechanical Installation

3.1 Unpacking

3.1.1 Items Supplied

Items supplied may vary according to product configuration.

- Make sure the items supplied and the information on the nameplate correspond to the order confirmation.
- Check the packaging and the frequency converter visually for damage caused by inappropriate handling during shipment. File any claim for damage with the carrier. Retain damaged parts for clarification.

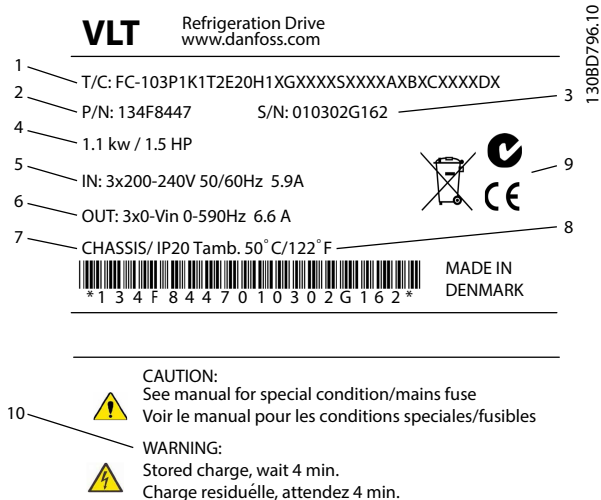

1	Type code
2	Ordering number
3	Serial number
4	Power rating
5	Input voltage, frequency, and current (at low/high voltages)
6	Output voltage, frequency, and current (at low/high voltages)
7	Enclosure size and IP protection rating
8	Maximum ambient temperature
9	Certifications
10	Discharge time (Warning)

Illustration 3.1 Product Nameplate (Example)

NOTICE

Do not remove the nameplate from the frequency converter (loss of warranty).

3.1.2 Storage

Ensure that the requirements for storage are fulfilled. Refer to *chapter 8.4.1 Ambient Conditions* for further details.

3.2 Installation Environments

NOTICE

In environments with airborne liquids, particles, or corrosive gases, ensure that the IP/type rating of the equipment matches the installation environment. Failure to meet requirements for ambient conditions can reduce the lifetime of the frequency converter. Ensure that requirements for air humidity, temperature, and altitude are met.

Voltage [V]	Altitude restrictions
380–500	At altitudes above 3000 m (9842 ft), contact Danfoss regarding PELV.
525–690	At altitudes above 2000 m (6562 ft), contact Danfoss regarding PELV.

Table 3.1 Installation at High Altitudes

For detailed ambient conditions specifications, refer to *chapter 8.4.1 Ambient Conditions*.

3.3 Mounting

NOTICE

Improper mounting can result in overheating and reduced performance.

Cooling

- Ensure that top and bottom clearance for air cooling is provided. Clearance requirement: 225 mm (9 in).
- Consider derating for temperatures starting between 45 °C (113 °F) and 50 °C (122 °F) and elevation 1000 m (3300 ft) above sea level. See the frequency converter *design guide* for detailed information.

The frequency converter utilizes a back-channel cooling concept that removes heat sink cooling air. The heat sink cooling air carries approximately 90% of the heat out of the back channel of the frequency converter. Redirect the back-channel air from the panel or room by using:

- Duct cooling. A back-channel cooling kit is available to direct the heat sink cooling air out of the panel when an IP20/chassis frequency converter is installed in a Rittal enclosure. Use of this kit reduces the heat in the panel and smaller door fans can be specified on the enclosure.
- Cooling out the back (top and base covers). The back-channel cooling air can be ventilated out of the room so that the heat from the back channel is not dissipated into the control room.

NOTICE

One or more door fans are required on the enclosure to remove the heat not contained in the back channel of the frequency converter. The fans also remove any additional losses generated by other components inside the frequency converter. To select the appropriate fan, calculate the total required airflow.

Secure the necessary airflow over the heat sink. The flow rate is shown in Table 3.2.

Enclosure size	Door fan/top fan	Heat sink fan
D1h/D3h/D5h/D6h	102 m ³ /hr (60 CFM)	420 m ³ /hr (250 CFM)
D2h/D4h/D7h/D8h	204 m ³ /hr (120 CFM)	840 m ³ /hr (500 CFM)

Table 3.2 Airflow

Lifting

Always lift the frequency converter using the dedicated lifting eyes. To avoid bending the lifting holes, use a lifting bar.

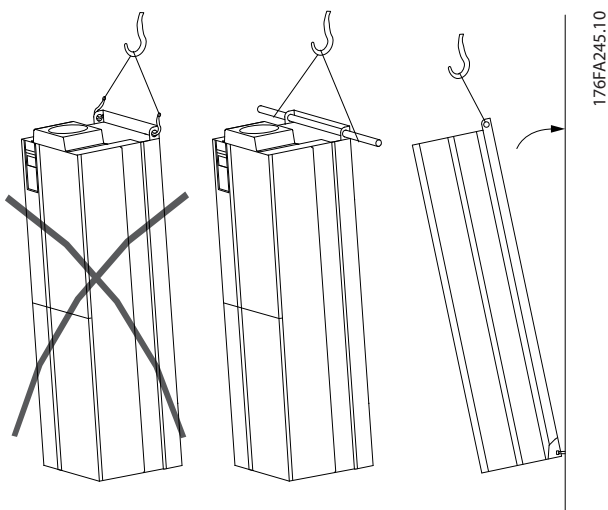

Illustration 3.2 Recommended Lifting Method

WARNING

RISK OF INJURY OR DEATH

The lifting bar must be able to support the weight of the frequency converter to ensure that it does not break during lifting.

- See chapter 8.9 Power Ratings, Weight, and Dimensions for the weight of the different enclosure sizes.
- Maximum diameter for bar: 25 mm (1 in).
- The angle from the top of the frequency converter to the lifting cable: 60° or greater.

Failure to follow recommendations could result in death or serious injury.

Mounting

1. Ensure that the strength of the mounting location supports the unit weight.
2. Place the unit as near to the motor as possible. Keep the motor cables as short as possible.
3. Mount the unit vertically to a solid flat surface to provide cooling airflow. Ensure free space for cooling.
4. Ensure the access, to open the door.
5. Ensure the cable entry from below.

4 Electrical Installation

4.1 Safety Instructions

See *chapter 2 Safety* for general safety instructions.

⚠ WARNING

INDUCED VOLTAGE

Induced voltage from output motor cables that run together can charge equipment capacitors, even with the equipment turned off and locked out. Failure to run output motor cables separately or use shielded cables could result in death or serious injury.

- Run output motor cables separately, or
- Use shielded cables.

⚠ CAUTION

SHOCK HAZARD

The frequency converter can cause a DC current in the PE conductor. Failure to follow the recommendation means that the RCD may not provide the intended protection.

- When a residual current-operated protective device (RCD) is used for protection against electrical shock, only an RCD of Type B is allowed on the supply side.

Overcurrent protection

- More protective equipment, such as short-circuit protection or motor thermal protection between frequency converter and motor, is required for applications with multiple motors.
- Input fusing is required to provide short-circuit and overcurrent protection. If not factory-supplied, the installer must provide the fuses. See maximum fuse ratings in *chapter 8.7 Fuses*.

Wire type and ratings

- All wiring must comply with local and national regulations regarding cross-section and ambient temperature requirements.
- Power connection wire recommendation: Minimum 75 °C (167 °F) rated copper wire.

See *chapter 8.1 Electrical Data* and *chapter 8.5 Cable Specifications* for recommended wire sizes and types.

4.2 EMC-compliant Installation

To obtain an EMC-compliant installation, follow the instructions provided in:

- *Chapter 4.4 Wiring Schematic*.
- *Chapter 4.6 Motor Connection*.
- *Chapter 4.3 Grounding*.
- *Chapter 4.8.1 Control Wiring*.

4.3 Grounding

⚠ WARNING

LEAKAGE CURRENT HAZARD

Leakage currents exceed 3.5 mA. Failure to ground the drive properly can result in death or serious injury.

- Ensure the correct grounding of the equipment by a certified electrical installer.

For electrical safety

- Ground the frequency converter in accordance with applicable standards and directives.
- Use a dedicated ground wire for input power, motor power, and control wiring.
- Do not ground 1 frequency converter to another in a daisy chain fashion.
- Keep the ground wire connections as short as possible.
- Follow motor manufacturer wiring requirements.
- Minimum cable cross-section: 10 mm² (6 AWG) (or 2 rated ground wires terminated separately).
- Tighten the terminals in accordance with the information provided in *Table 8.9*.

For EMC-compliant installation

- Establish electrical contact between the cable shield and the frequency converter enclosure by using metal cable glands or by using the clamps provided on the equipment.
- Reduce burst transient by using high-strand wire.
- Do not use pigtailed.

NOTICE

POTENTIAL EQUALIZATION

There is a risk of burst transient when the ground potential between the frequency converter and the control system is different. Install equalizing cables between the system components. Recommended cable cross-section: 16 mm² (5 AWG).

4

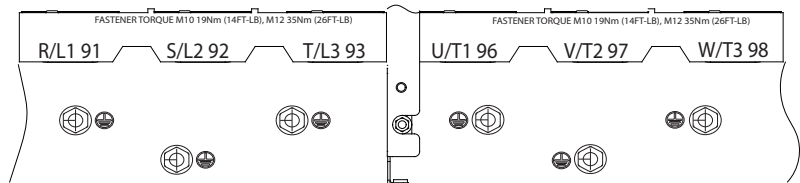
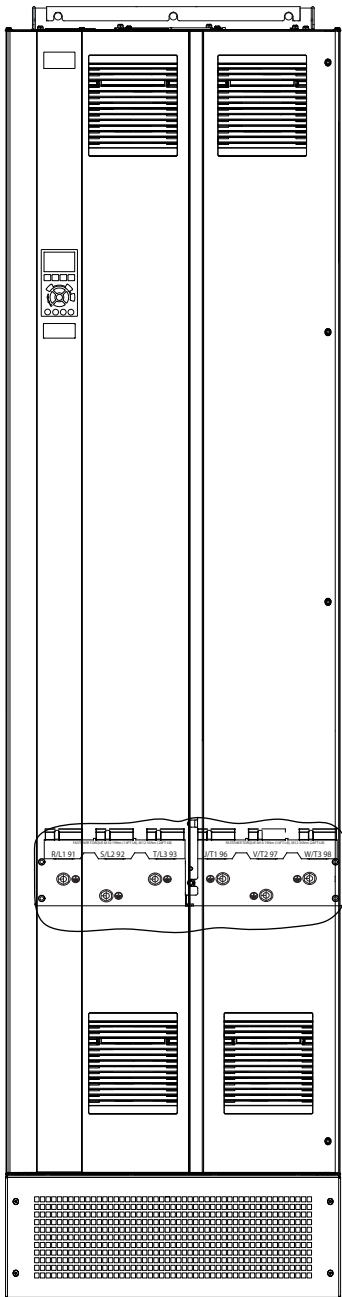

1	Ground terminal (ground terminals are marked with symbol)	2	Ground symbol
---	---	---	---------------

Illustration 4.1 Ground Terminals (D1h shown)

4.4 Wiring Schematic

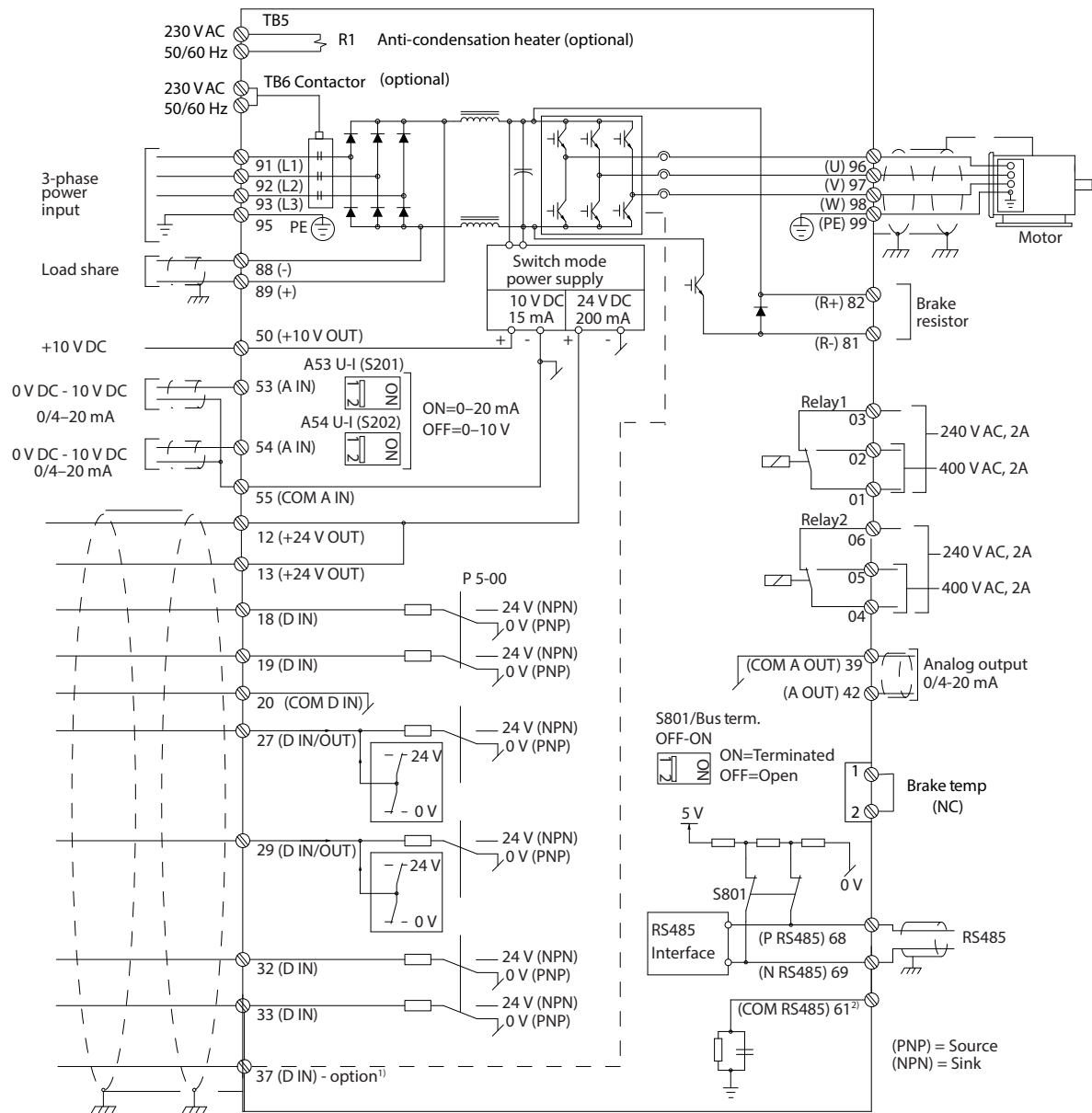

130BC548.14

Illustration 4.2 Basic Wiring Schematic

A=Analog, D=Digital

- 1) Terminal 37 (optional) is used for Safe Torque Off. For Safe Torque Off installation instructions, refer to the VLT® Frequency Converters - Safe Torque Off Operating Guide.
- 2) Do not connect cable shield.

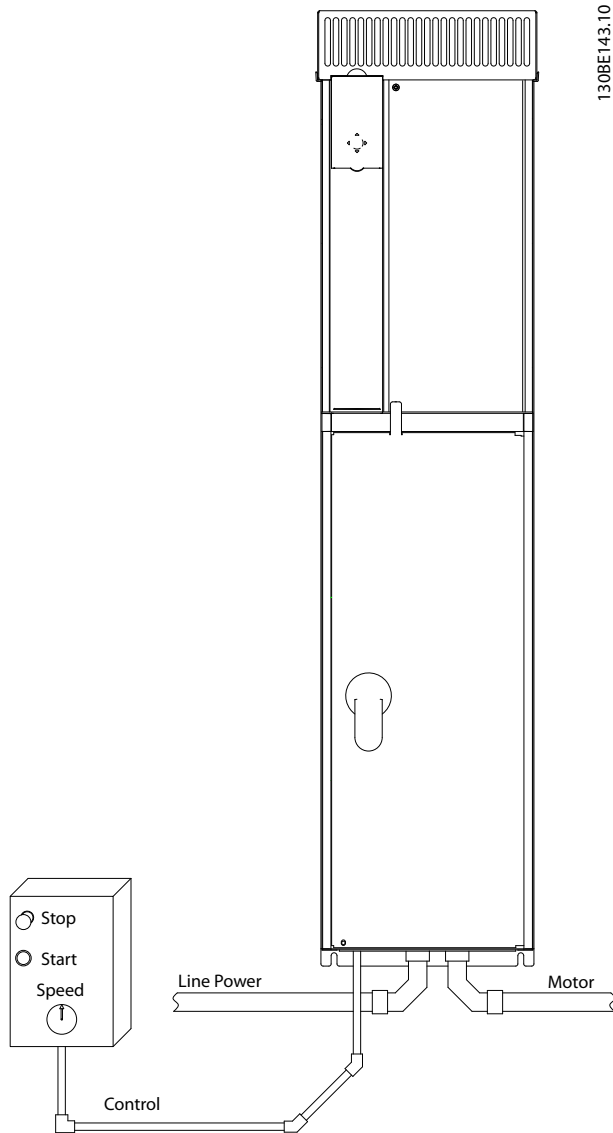

Illustration 4.3 Example of Proper Electrical Installation Using Conduit

NOTICE

EMC INTERFERENCE

Use shielded cables for motor and control wiring, and separate cables for mains input, motor wiring, and control wiring. Failure to isolate power, motor, and control cables can result in unintended behavior or reduced performance. Minimum 200 mm (7.9 in) clearance between mains input, motor, and control cables is required.

4.5 Access

All terminals to the control cables are inside the drive below the LCP. To access, either open the door (E1h and E2h) or remove the front panel (E3h and E4h).

4.6 Motor Connection

WARNING
INDUCED VOLTAGE

Induced voltage from output motor cables that run together can charge equipment capacitors, even with the equipment turned off and locked out. Failure to run output motor cables separately or use shielded cables could result in death or serious injury.

- Comply with local and national electrical codes for cable sizes. For maximum wire sizes, see *chapter 8.1 Electrical Data*.
- Follow motor manufacturer wiring requirements.
- Motor wiring knockouts or access panels are provided at the base of IP21 (NEMA1/12) and higher units.
- Do not wire a starting or pole-changing device (for example Dahlander motor or slip ring asynchronous motor) between the frequency converter and the motor.

Procedure

1. Strip a section of the outer cable insulation.
2. Position the stripped wire under the cable clamp to establish mechanical fixation and electrical contact between the cable shield and ground.
3. Connect the ground wire to the nearest grounding terminal in accordance with the grounding instructions provided in *chapter 4.3 Grounding*, see *Illustration 4.4*.
4. Connect the 3-phase motor wiring to terminals 96 (U), 97 (V), and 98 (W), see *Illustration 4.4*.
5. Tighten the terminals in accordance with the information provided in *chapter 8.8 Connection Tightening Torques*.

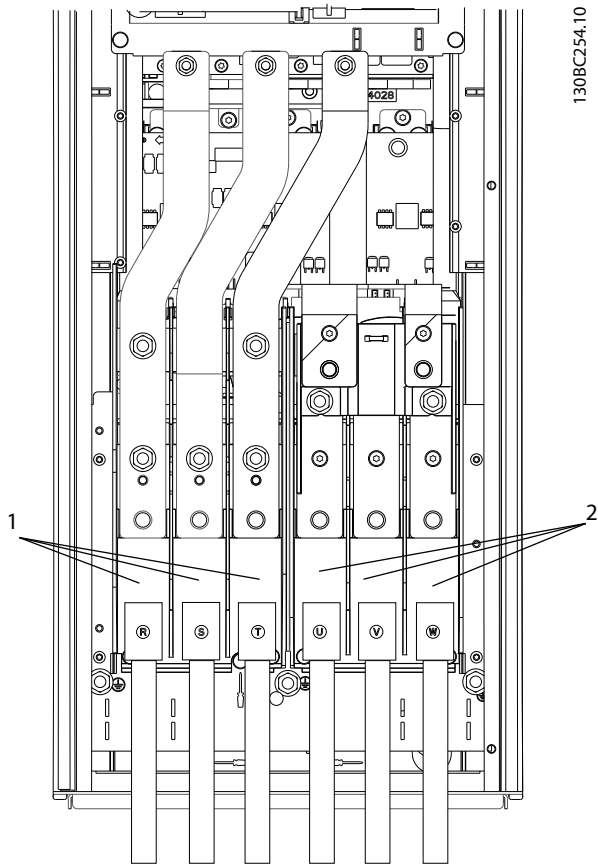

1	Mains connection (R, S, T)
2	Motor connection (U, V, W)

Illustration 4.4 Motor Connection

4

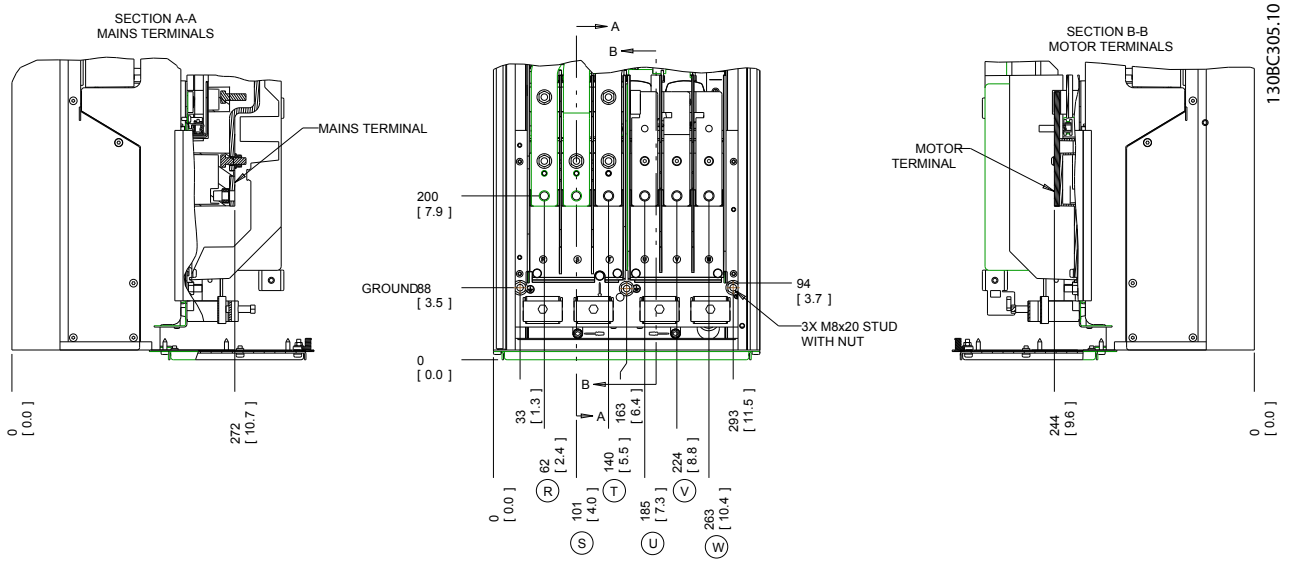

Illustration 4.5 Terminal Locations, D1h

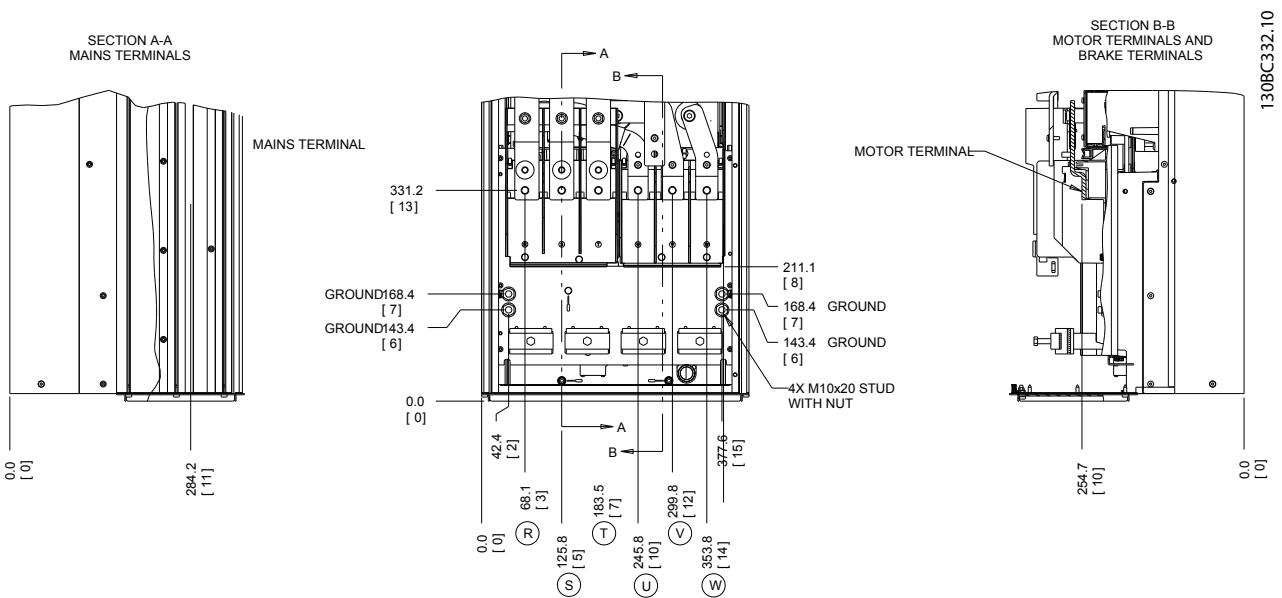

Illustration 4.6 Terminal Locations, D2h

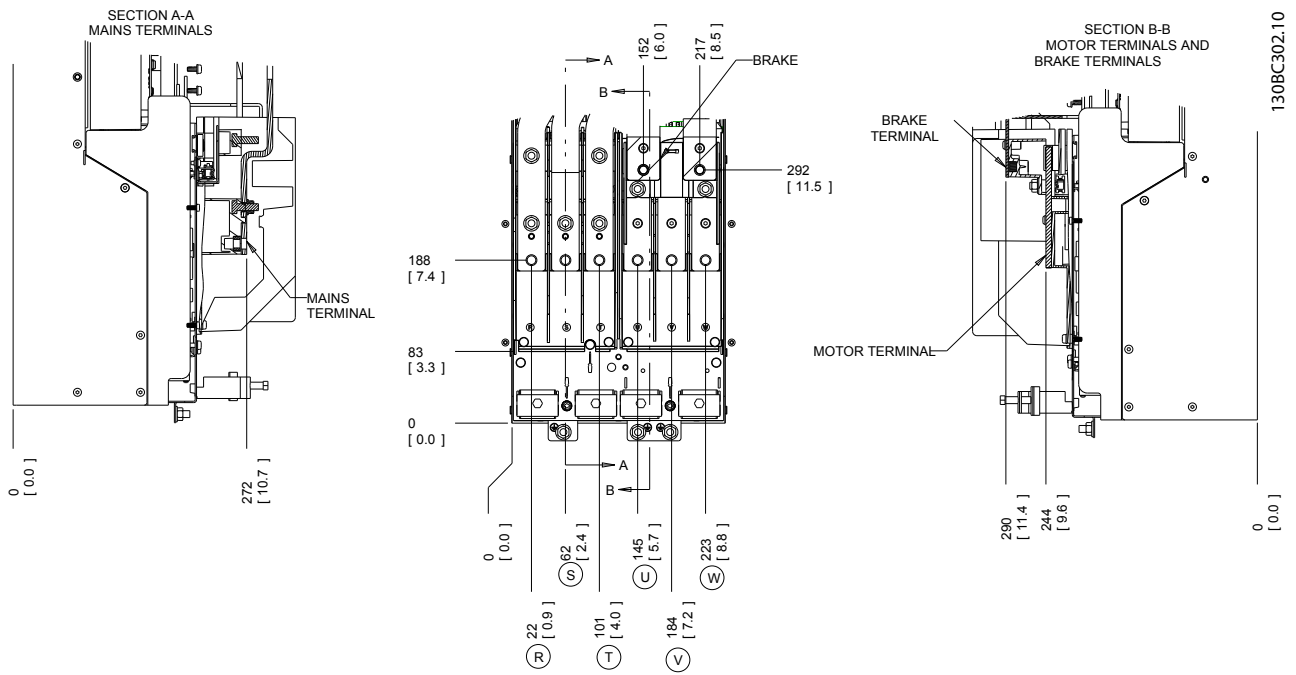
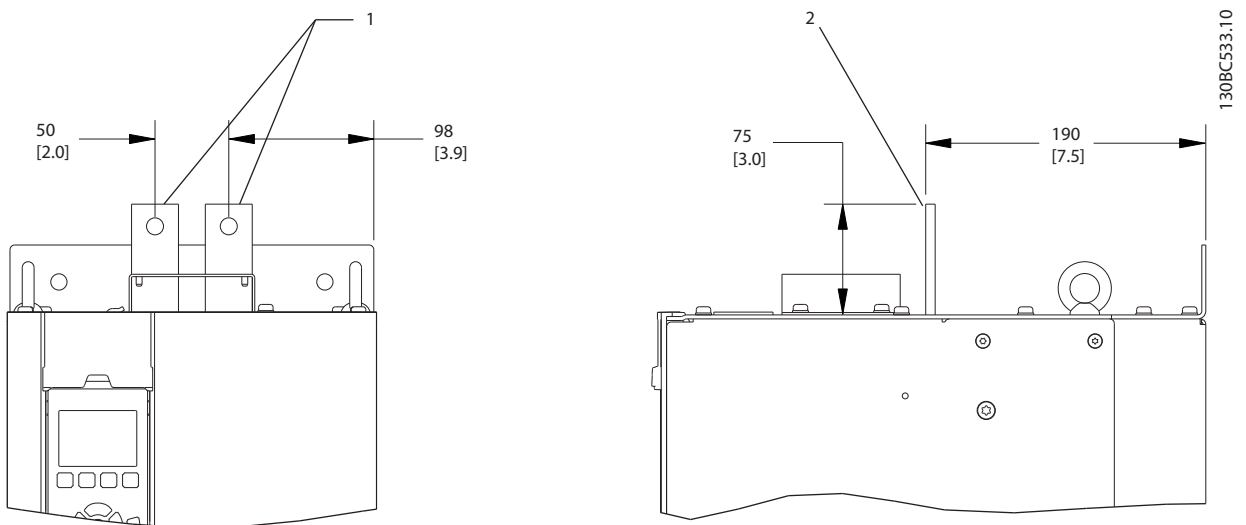

Illustration 4.7 Terminal Locations, D3h



1	Front view
2	Side view

Illustration 4.8 Load Sharing and Regeneration Terminals, D3h

4

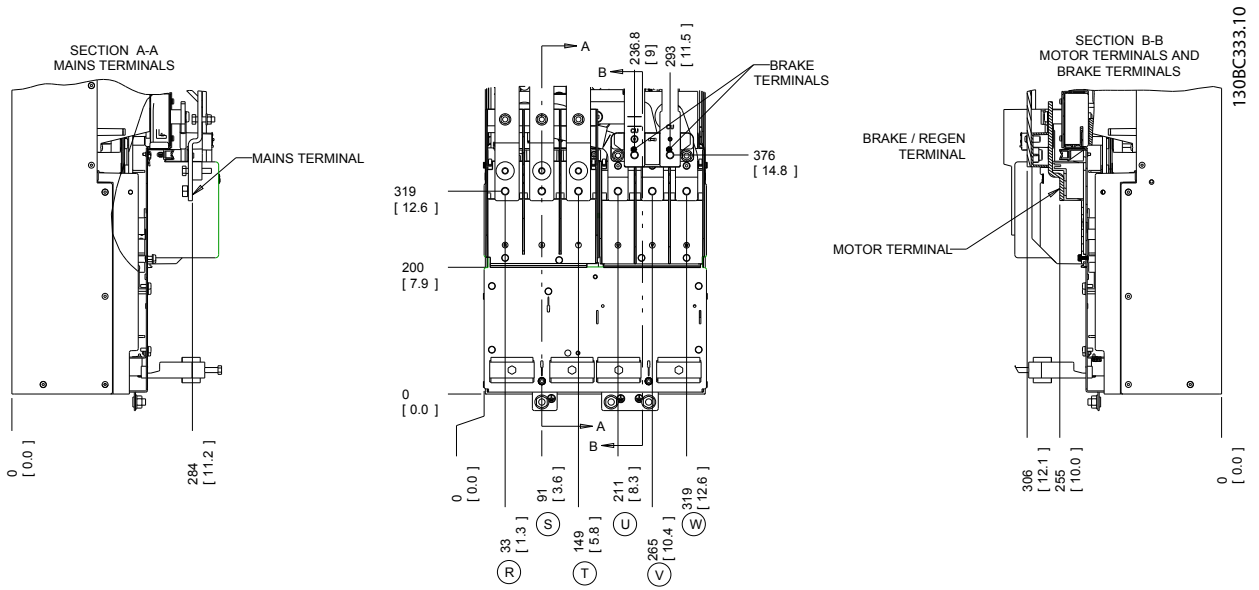
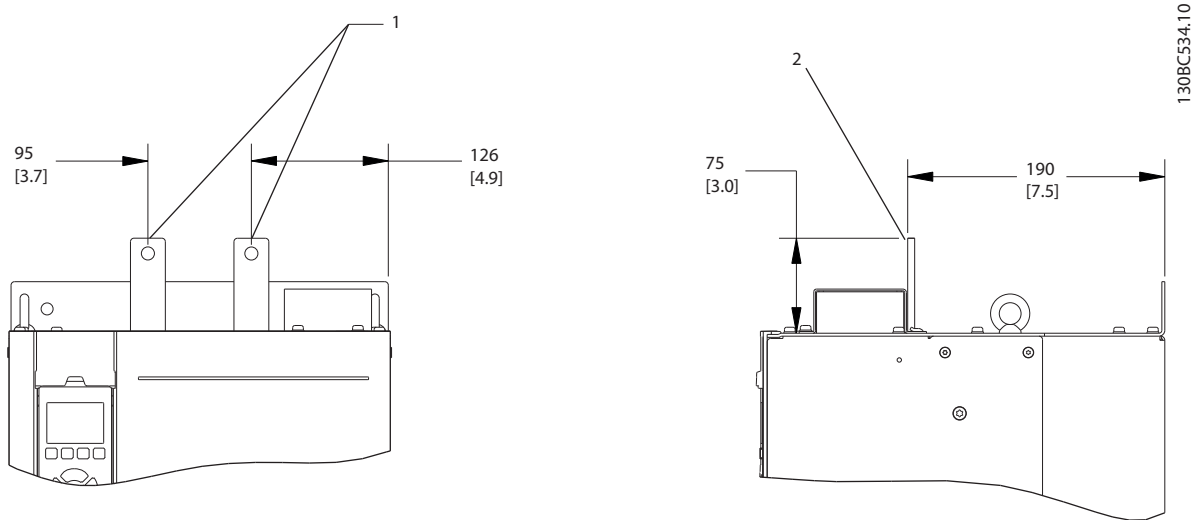
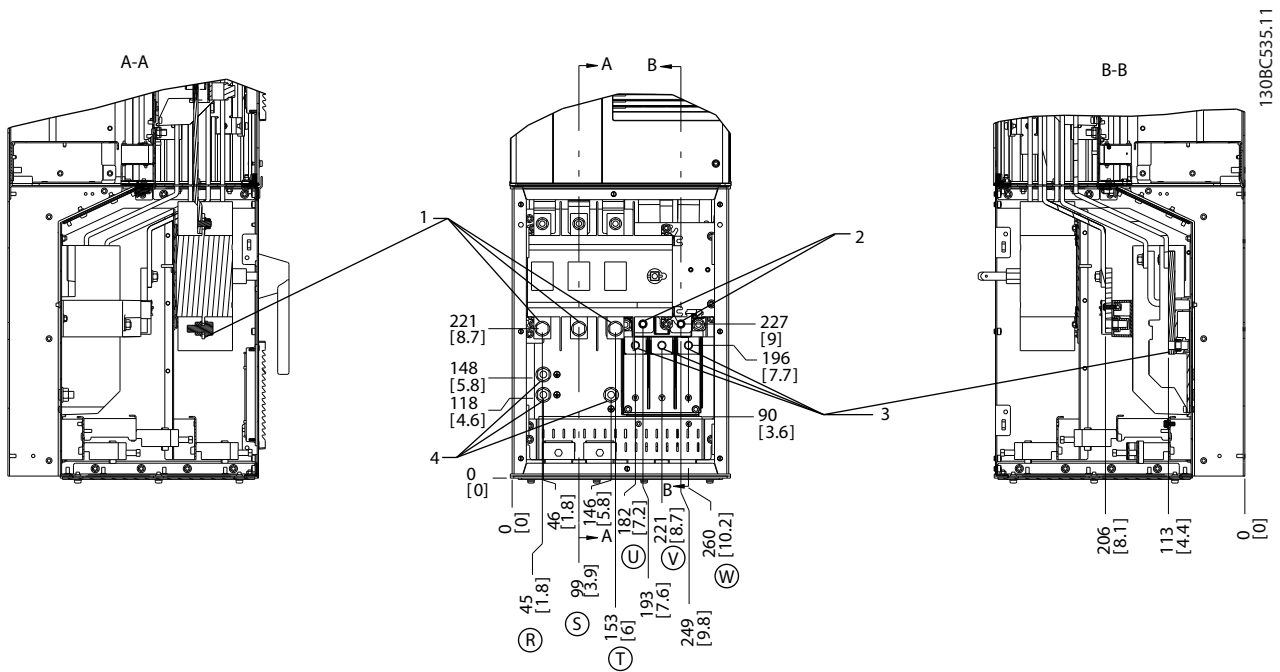

Illustration 4.9 Terminal Locations, D4h



1	Front view
2	Side view

Illustration 4.10 Load Sharing and Regeneration Terminals, D4h



1308C535.11

4

1	Mains terminals
2	Brake terminals
3	Motor terminals
4	Ground terminals

Illustration 4.11 Terminal Locations, D5h with Disconnect Option

4

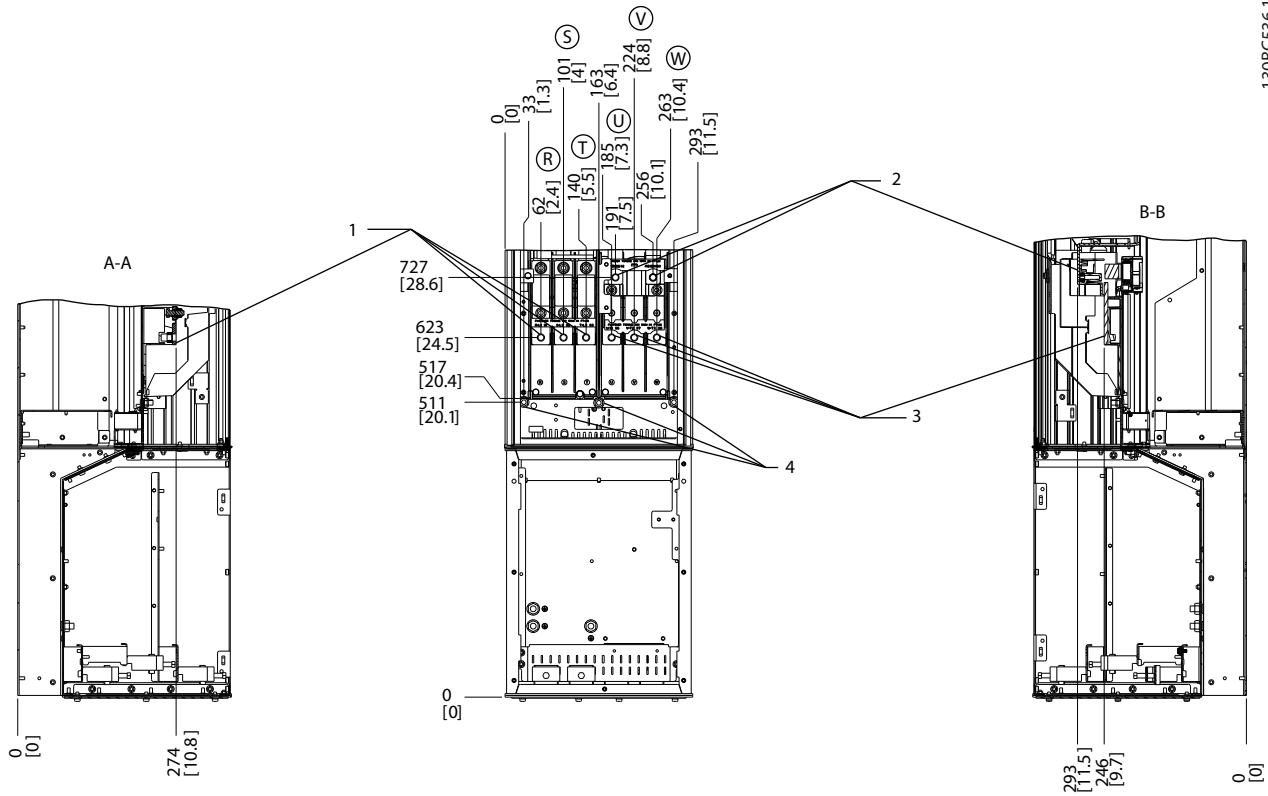

130BC536.11

1	Mains terminals
2	Brake terminals
3	Motor terminals
4	Ground terminals

Illustration 4.12 Terminal Locations, D5h with Brake Option

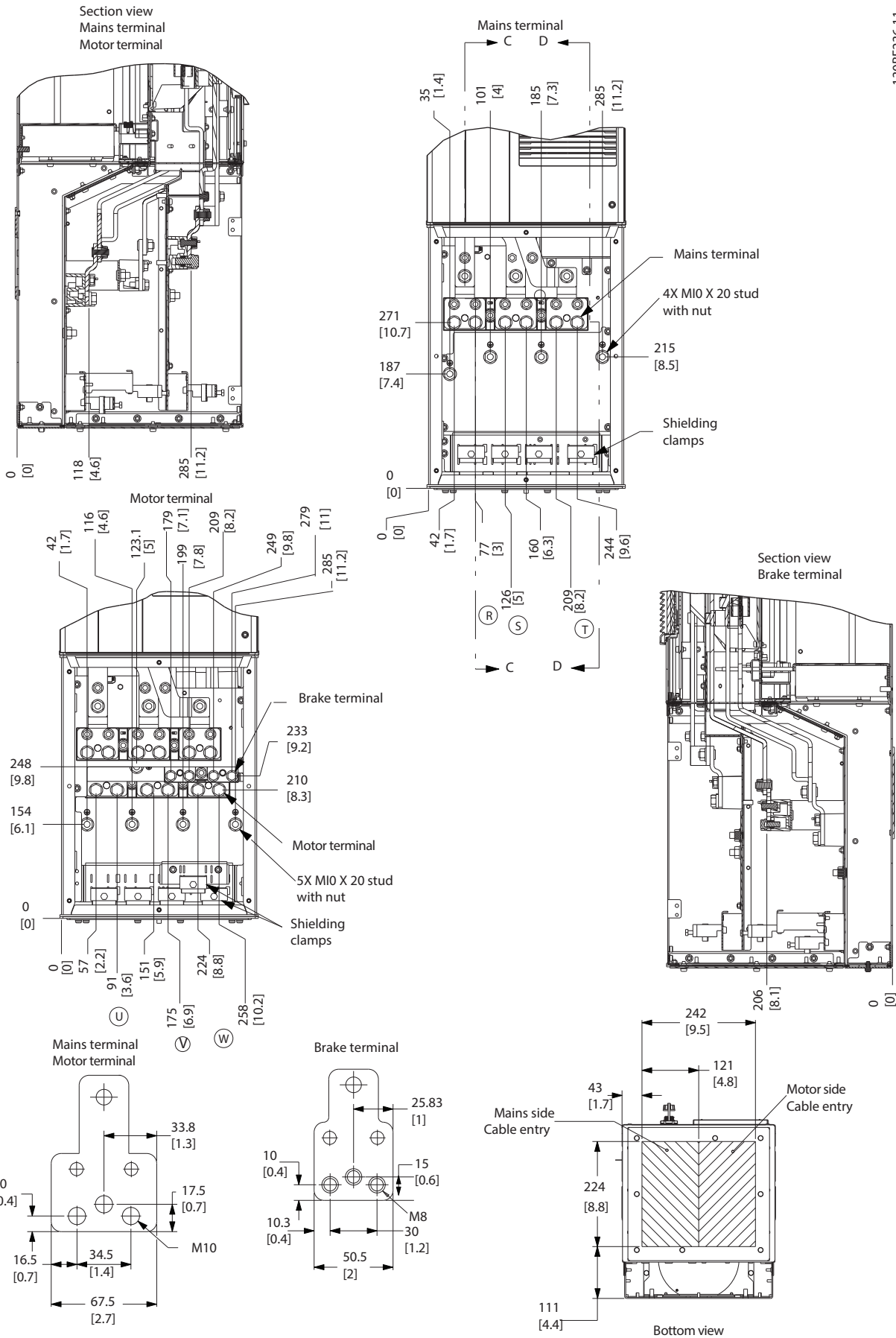
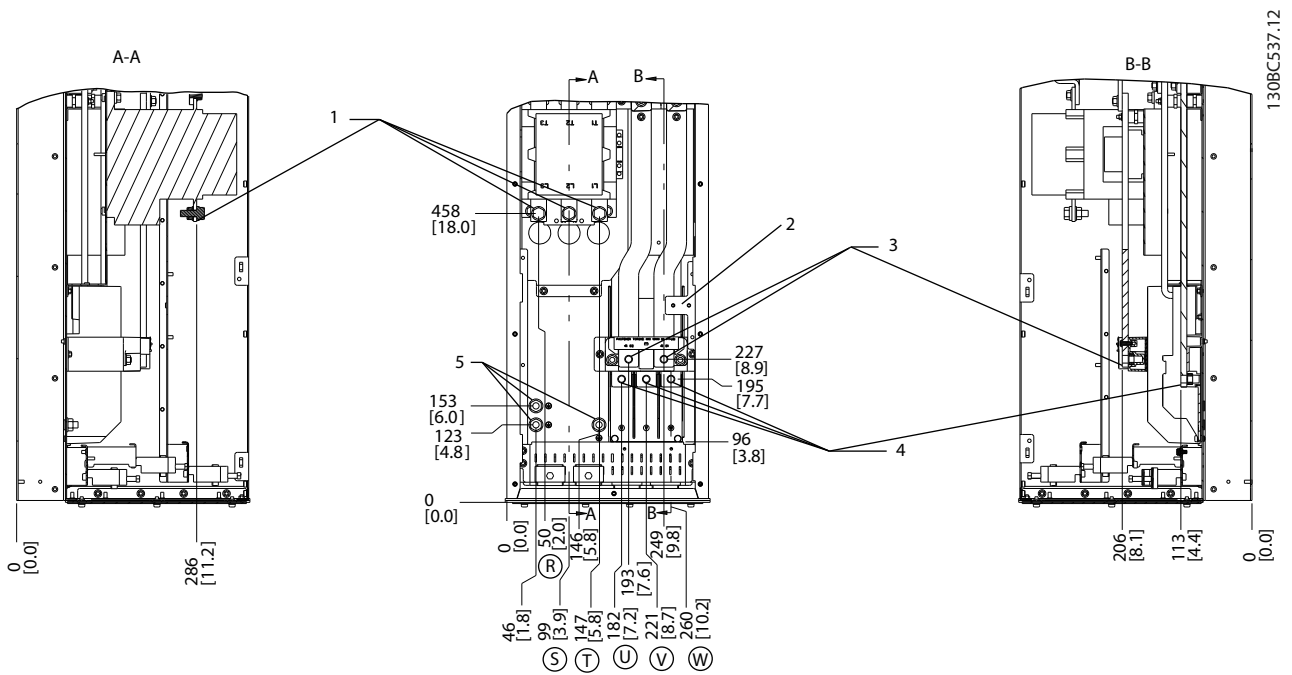

Illustration 4.13 Oversized Wiring Cabinet, D5H

4



1	Mains terminals
2	TB6 terminal block for contactor
3	Brake terminals
4	Motor terminals
5	Ground terminals

Illustration 4.14 Terminal Locations, D6h with Contactor Option

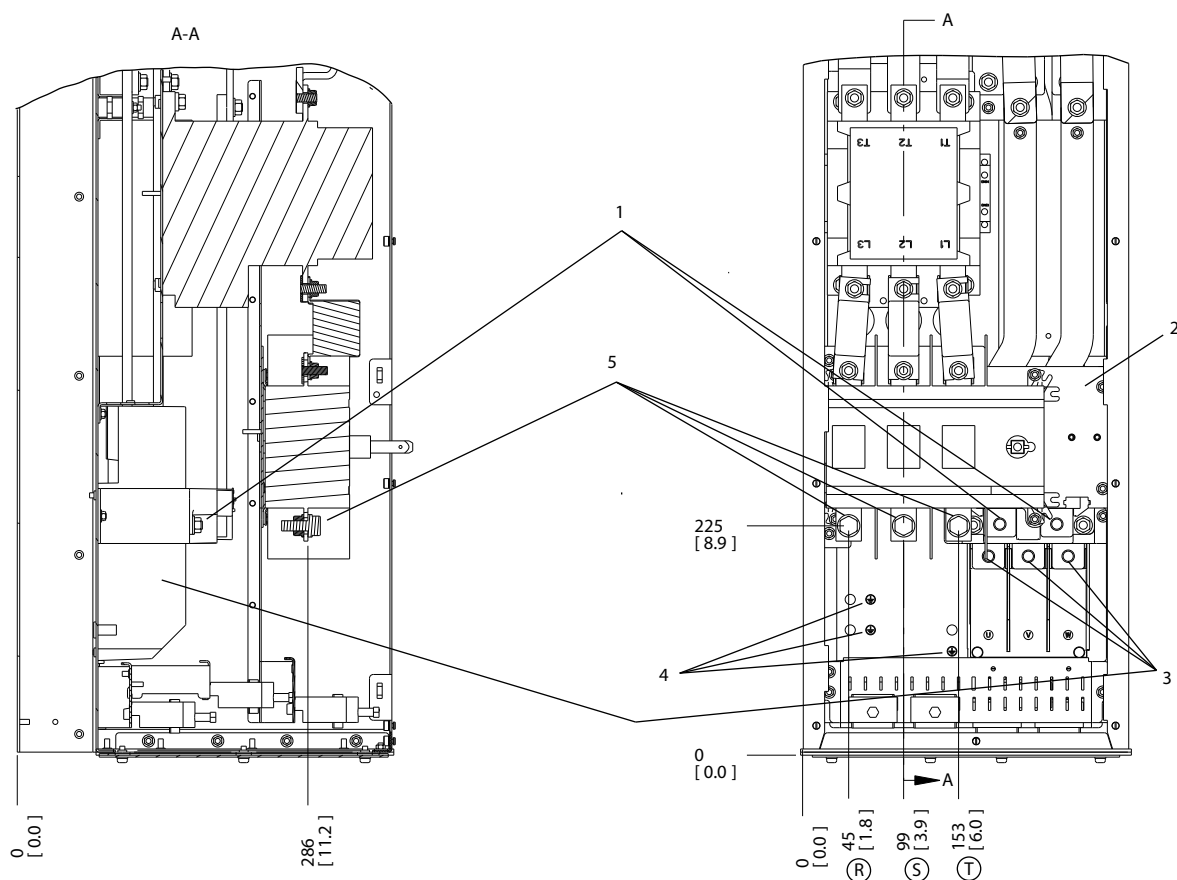

130BC538.12

4

1	Brake terminals
2	TB6 terminal block for contactor
3	Motor terminals
4	Ground terminals
5	Mains terminals

Illustration 4.15 Terminal Locations, D6h with Contactor and Disconnect Options

4

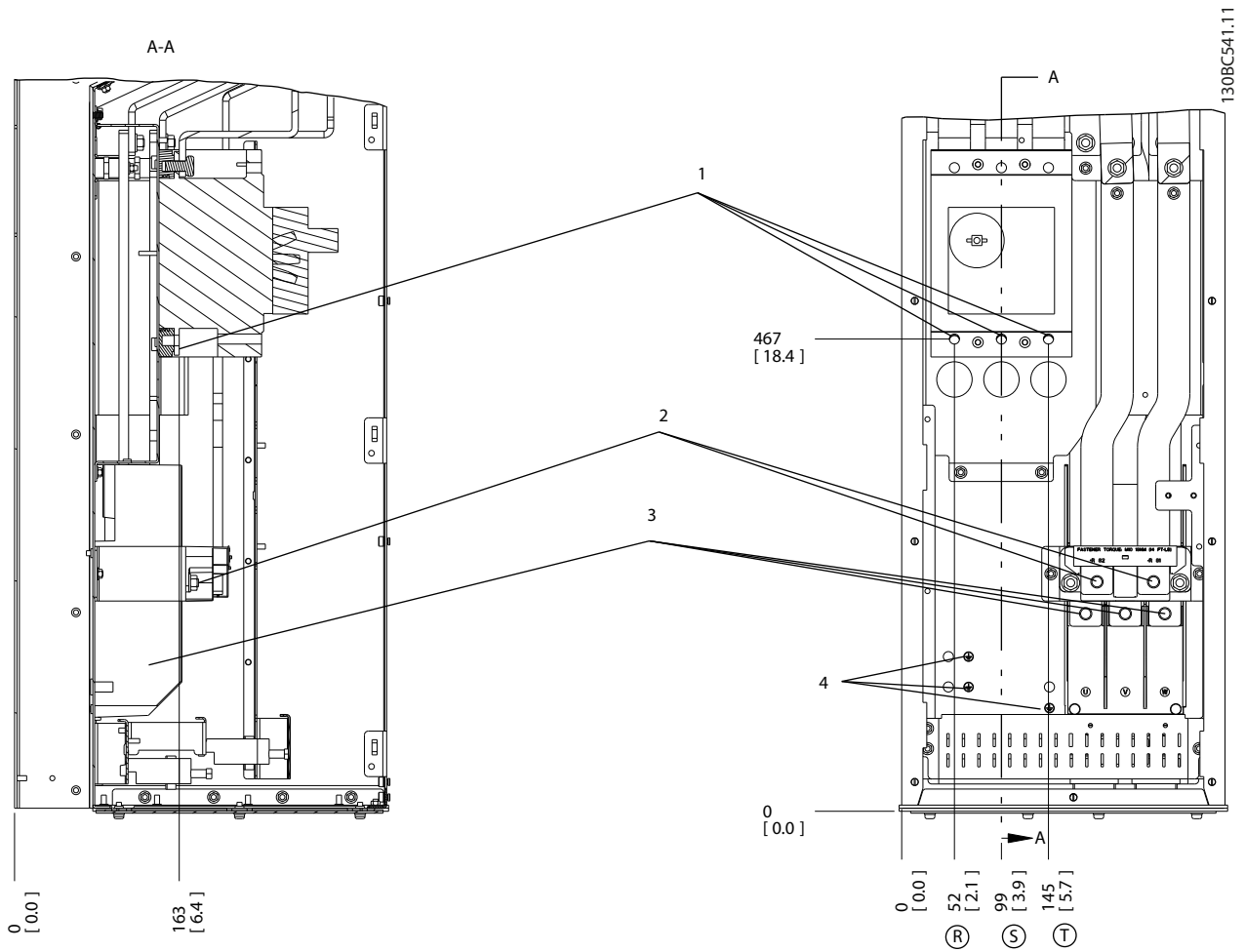

1	Mains terminals
2	Brake terminals
3	Motor terminals
4	Ground terminals

Illustration 4.16 Terminal Locations, D6h with Circuit Breaker Option

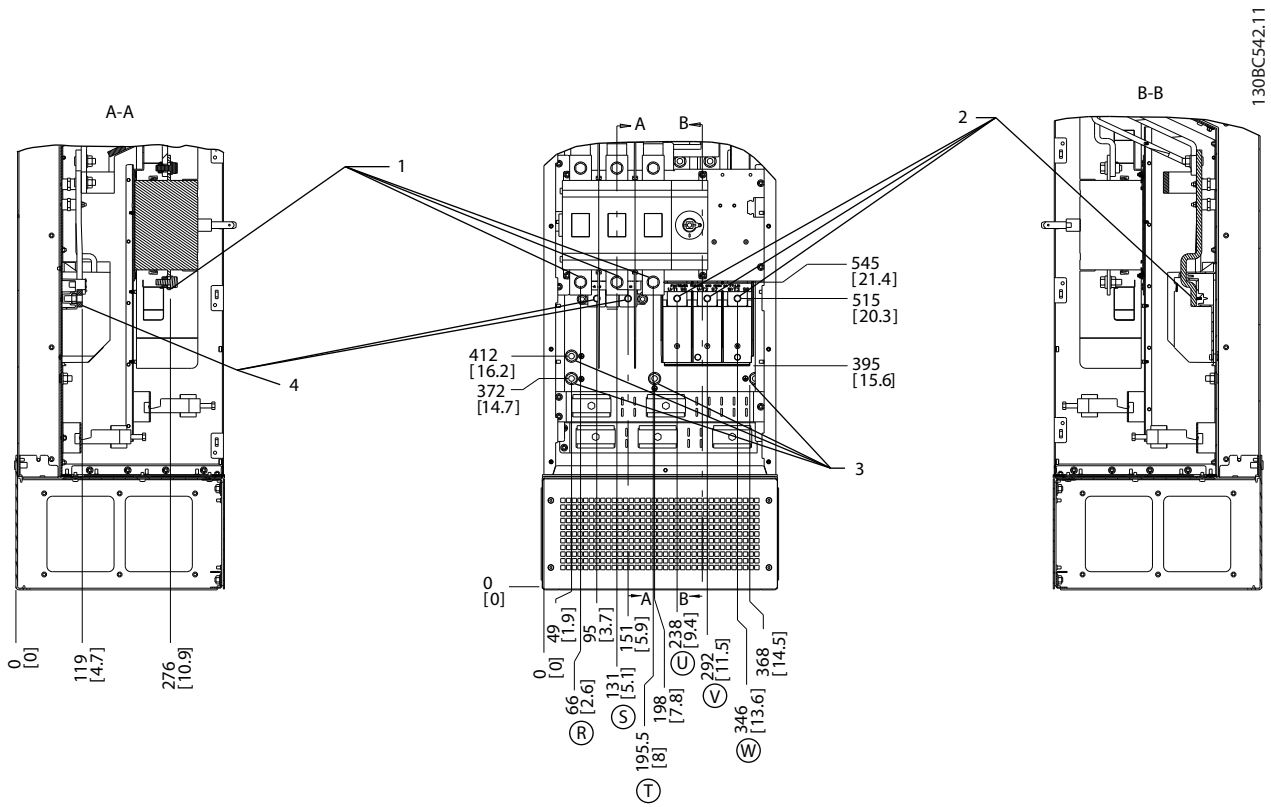

1308C542.11

4

1	Mains terminals
2	Motor terminals
3	Ground terminals
4	Brake terminals

Illustration 4.17 Terminal Locations, D7h with Disconnect Option

4

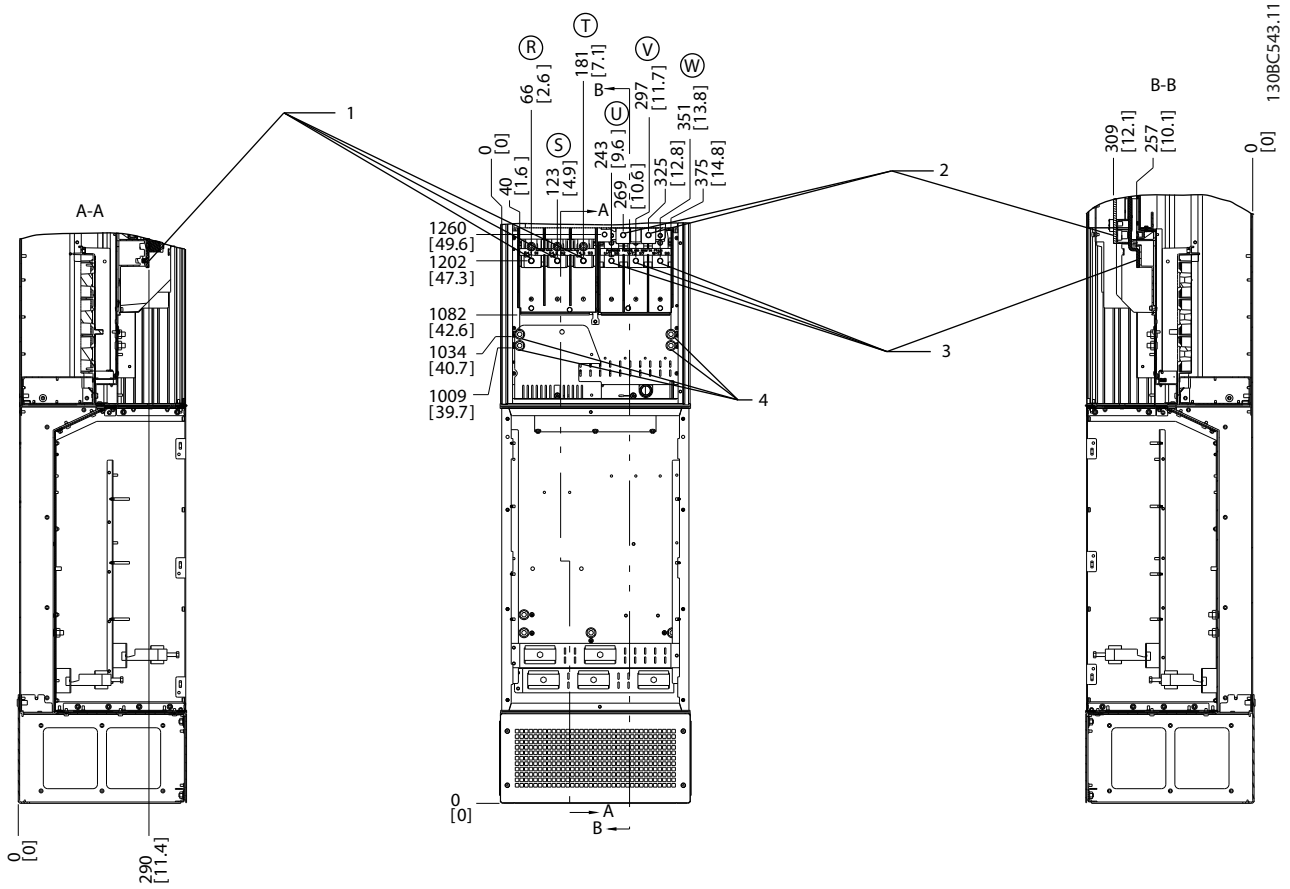

1	Mains terminals
2	Brake terminals
3	Motor terminals
4	Ground terminals

Illustration 4.18 Terminal Locations, D7h with Brake Option

130BE237.11

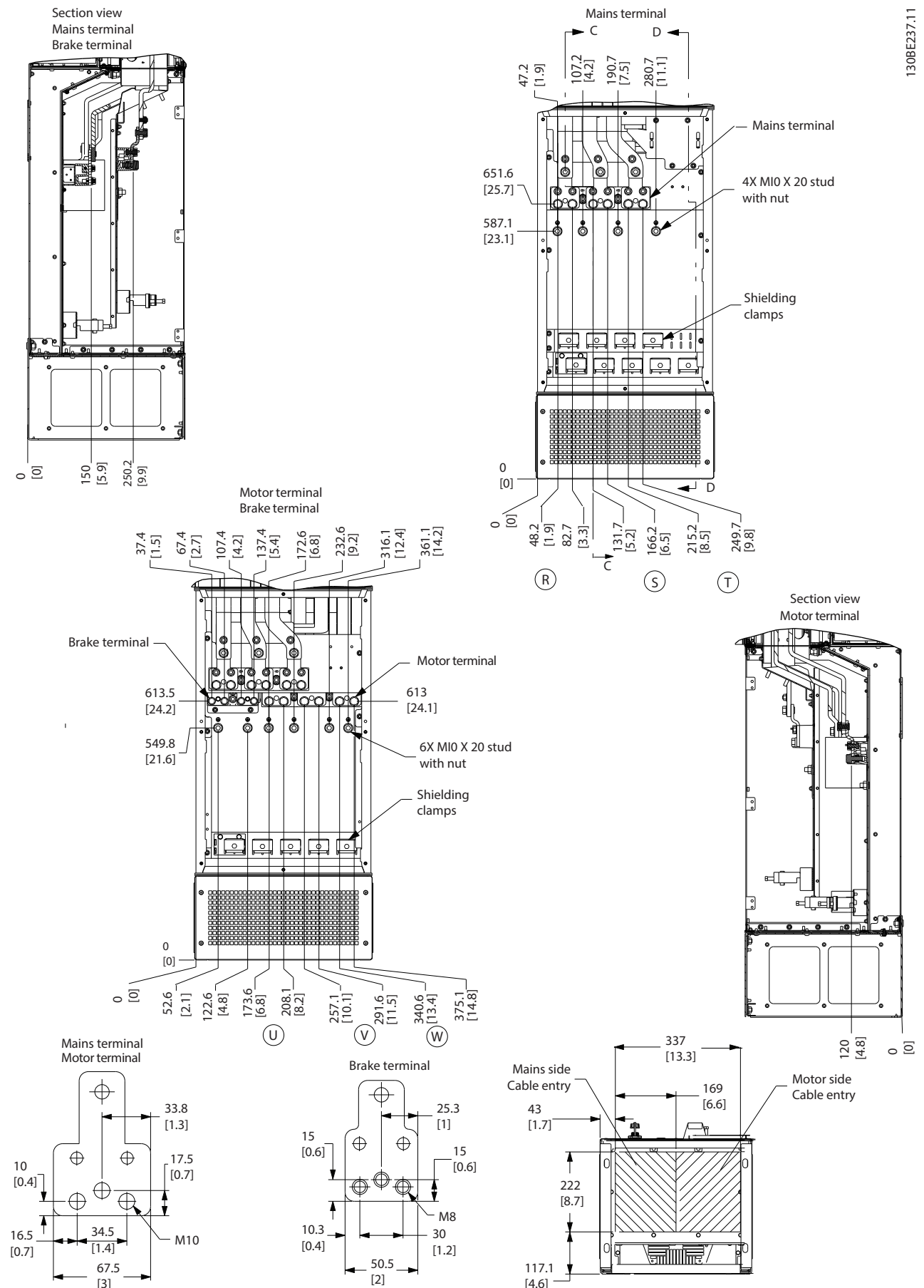
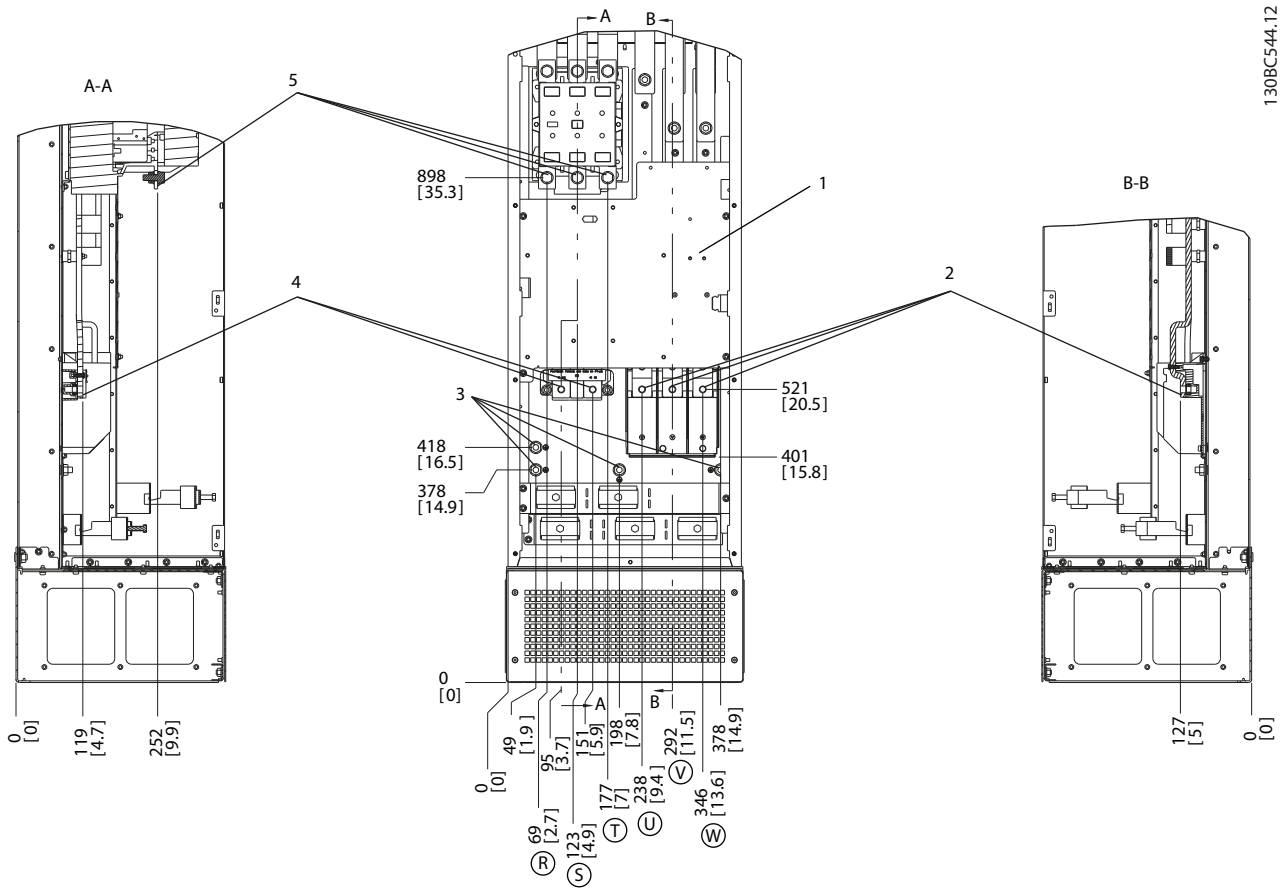

Illustration 4.19 Oversized Wiring Cabinet, D7h

4



1.30BC544.12

1	TB6 terminal block for contactor	4	Brake terminals
2	Motor terminals	5	Mains terminals
3	Ground terminals		

Illustration 4.20 Terminal Locations, D8h with Contactor Option

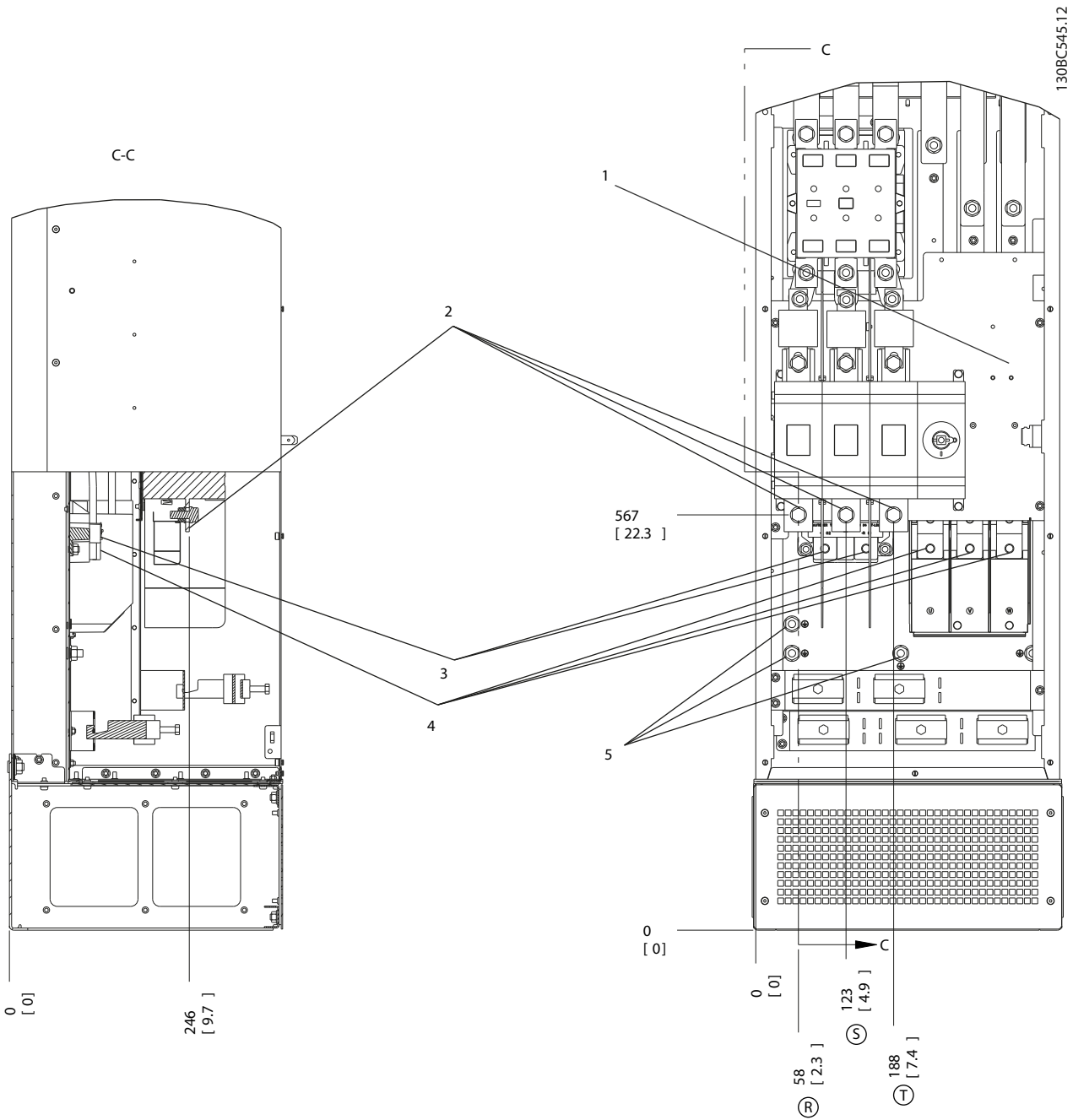

130BC545.12

4

1	TB6 terminal block for contactor	4	Motor terminals
2	Mains terminals	5	Ground terminals
3	Brake terminals		

Illustration 4.21 Terminal Locations, D8h with Contactor and Disconnect Options

4

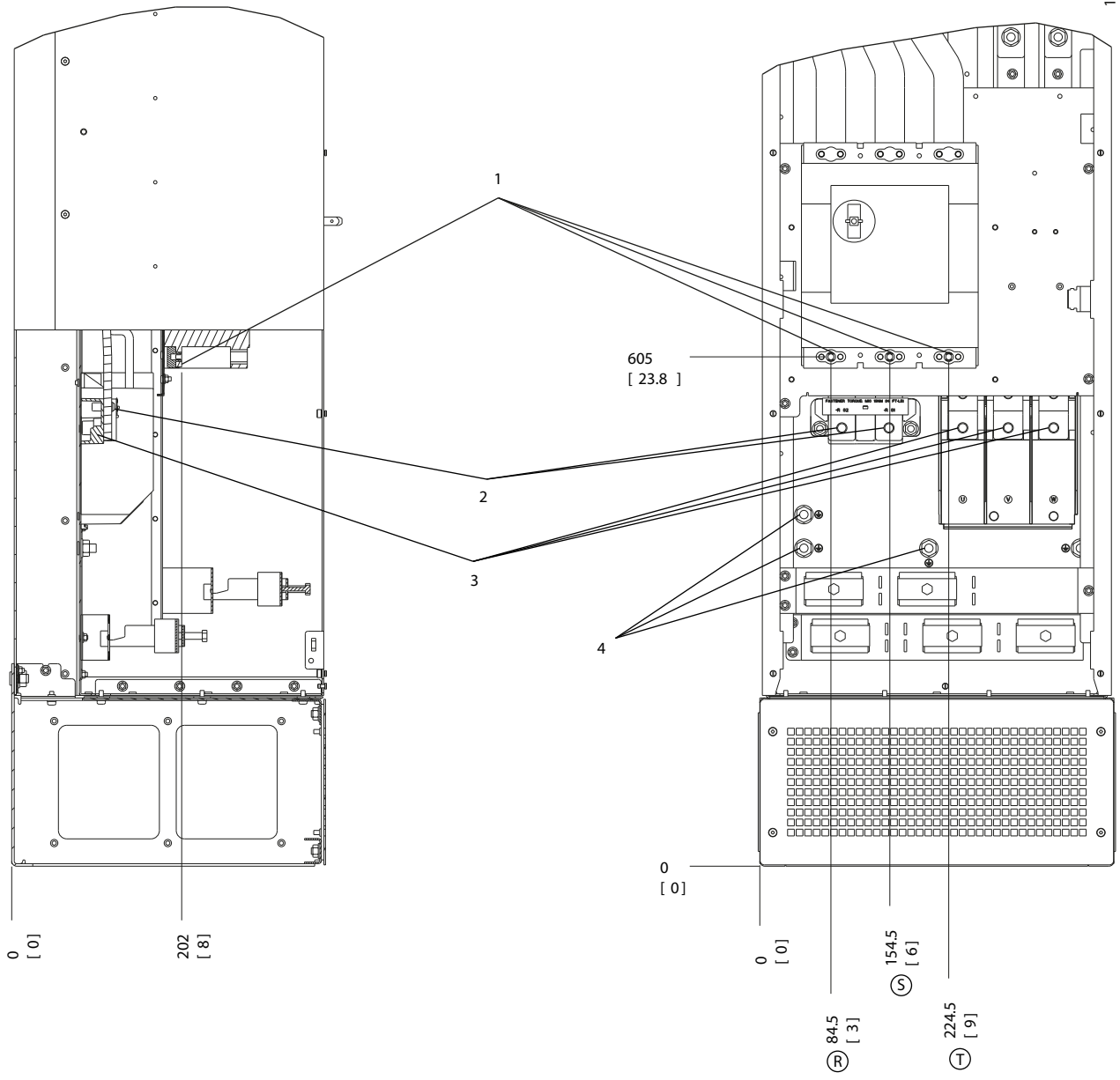

1	Mains terminals	3	Motor terminals
2	Brake terminals	4	Ground terminals

Illustration 4.22 Terminal Locations, D8h with Circuit Breaker Option

4.7 AC Mains Connection

- Size the wiring according to the input current of the frequency converter. For maximum wire sizes, see *chapter 8.1 Electrical Data*.
- Comply with local and national electrical codes for cable sizes.

Procedure

1. Connect the 3-phase AC input power wiring to terminals R, S, and T (see *Illustration 4.23*).
2. Depending on the configuration of the equipment, connect the input power to the mains input terminals or the input disconnect.
3. Ground the cable in accordance with the grounding instructions provided in *chapter 4.3 Grounding*.
4. When supplied from an isolated mains source (IT mains or floating delta) or TT/TN-S mains with a grounded leg (grounded delta), ensure that *parameter 14-50 RFI Filter* is set to [0] Off. This setting prevents damage to the DC link and reduces ground capacity currents.

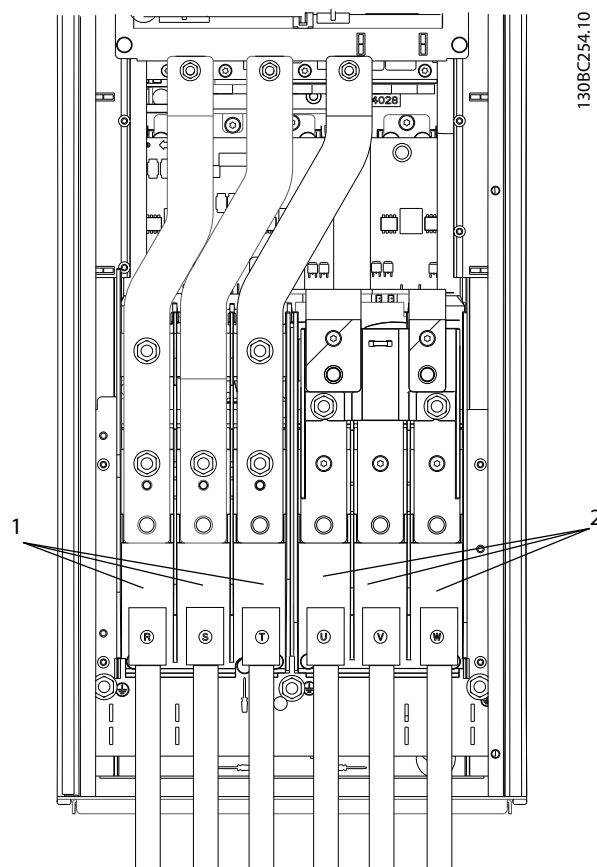

1	Mains connection (R, S, T)
2	Motor connection (U, V, W)

Illustration 4.23 Connecting to AC Mains

4.8 Control Wiring

- Isolate the control wiring from the high-power components in the frequency converter.
- When the frequency converter is connected to a thermistor, ensure that the thermistor control wiring is shielded and reinforced/double insulated. A 24 V DC supply voltage is recommended.

4.8.1 Control Terminal Types

Illustration 4.24 and Illustration 4.25 show the removable frequency converter connectors. Terminal functions and default settings are summarized in Table 4.1 and Table 4.3.

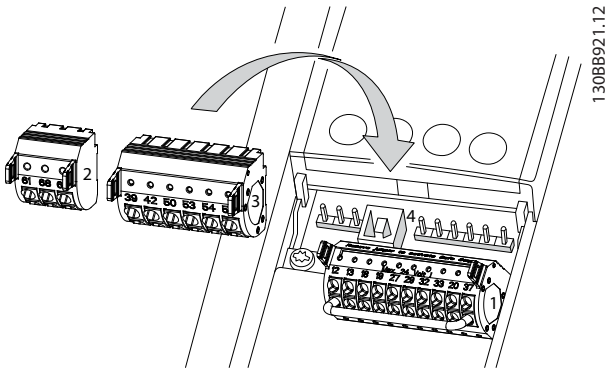

Illustration 4.24 Control Terminal Locations

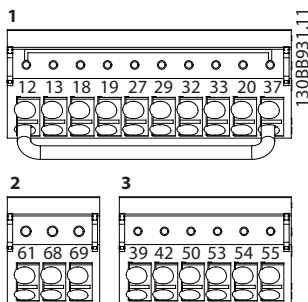

Illustration 4.25 Terminal Numbers

- Connector 1 provides 4 programmable digital input terminals, 2 extra digital terminals programmable as either input or output, a 24 V DC terminal supply voltage, and a common for optional customer-supplied 24 V DC voltage. VLT® Refrigeration Drive FC 103 also provides a digital input for STO function.
- Connector 2 terminals (+)68 and (-)69 for RS485 serial communication connection.
- Connector 3 provides 2 analog inputs, 1 analog output, 10 V DC supply voltage, and commons for the inputs and output.
- Connector 4 is a USB port available for use with the MCT 10 Set-up Software.

Terminal description			
Terminal	Parameter	Default setting	Description
12, 13	–	+24 V DC	24 V DC supply voltage for digital inputs and external transducers. Maximum output current 200 mA for all 24 V loads.
18	Parameter 5-10 Terminal 18 Digital Input	[8] Start	Digital inputs.
19	Parameter 5-11 Terminal 19 Digital Input	[10] Reversing	
32	Parameter 5-14 Terminal 32 Digital Input	[0] No operation	
33	Parameter 5-15 Terminal 33 Digital Input	[0] No operation	
27	Parameter 5-12 Terminal 27 Digital Input	[2] Coast inverse	For digital input or output. Default setting is input.
29	Parameter 5-13 Terminal 29 Digital Input	[14] Jog	
20	–	–	Common for digital inputs and 0 V potential for 24 V supply.
37	–	STO	Safe input.

Table 4.1 Terminal Description Digital Inputs/Outputs

Terminal description			
Terminal	Parameter	Default setting	Description
39	-		Common for analog output.
42	Parameter 6-50 Terminal 42 Output	[0] No operation	Programmable analog output. 0–20 mA or 4–20 mA at a maximum of 500 Ω.
50	-	+10 V DC	10 V DC analog supply voltage for potentiometer or thermistor. 15 mA maximum
53	Parameter group 6-5* Analog Output 42	Reference	Analog input. For voltage or current. Switches A53 and A54 select mA or V.
54	Parameter group 6-2* Analog Input 54	Feedback	
55	-	-	Common for analog input

Table 4.2 Terminal Description Analog Inputs/Outputs

Terminal description			
Terminal	Parameter	Default setting	Description
61	-		Integrated RC-filter for cable shield. ONLY for connecting the shield if EMC problems occur.
68 (+)	Parameter group 8-3* FC Port Settings	-	RS485 interface. A control card switch is provided for termination resistance.
69 (-)	Parameter group 8-3* FC Port Settings	-	

Table 4.3 Terminal Description Serial Communication

Terminal description			
Terminal	Parameter	Default setting	Description
01, 02, 03	Parameter 5-40 Function Relay	[0] No operation	Form C relay output. For AC or DC voltage and resistive or inductive loads.
04, 05, 06	Parameter 5-40 Function Relay [1]	[0] No operation	

Table 4.4 Terminal Description Relays

More terminals:

- 2 form C relay outputs. The location of the outputs depends on the frequency converter configuration.
- Terminals on built-in optional equipment. See the manual provided with the equipment option.

4.8.2 Wiring to Control Terminals

Control terminal connectors can be unplugged from the frequency converter for ease of installation as shown in Illustration 4.26.

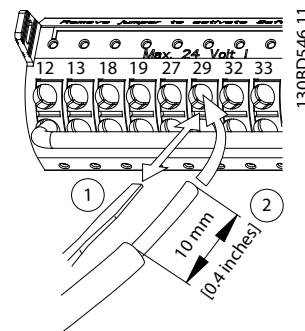

Illustration 4.26 Connecting Control Wires

NOTICE

Keep control wires as short as possible and separate them from high-power cables to minimize interference.

1. Open the contact by inserting a small screwdriver into the slot above the contact and push the screwdriver slightly upwards.
2. Insert the bare control wire into the contact.
3. Remove the screwdriver to fasten the control wire into the contact.
4. Ensure that the contact is firmly established and not loose. Loose control wiring can be the source of equipment faults or reduced performance.

See chapter 8.5 Cable Specifications for control terminal wiring sizes and chapter 6 Application Set-up Examples for typical control wiring connections.

4.8.3 Enabling Motor Operation (Terminal 27)

A jumper wire may be required between terminal 12 (or 13) and terminal 27 for the frequency converter to operate when using factory default programming values.

- Digital input terminal 27 is designed to receive a 24 V DC external interlock command.
- When no interlock device is used, wire a jumper between control terminal 12 (recommended) or 13 to terminal 27. This connection provides an internal 24 V signal on terminal 27.
- When the status line at the bottom of the LCP reads *AUTO REMOTE COAST*, it indicates that the unit is ready to operate but is missing an input signal on terminal 27.
- When factory-installed optional equipment is wired to terminal 27, do not remove that wiring.

NOTICE

The frequency converter cannot operate without a signal on terminal 27, unless terminal 27 is reprogrammed.

4.8.4 Voltage/Current Input Selection (Switches)

The analog input terminals 53 and 54 allow setting of input signal to voltage (0–10 V) or current (0/4–20 mA).

Default parameter setting:

- Terminal 53: Speed reference signal in open loop (see *parameter 16-61 Terminal 53 Switch Setting*).
- Terminal 54: Feedback signal in closed loop (see *parameter 16-63 Terminal 54 Switch Setting*).

NOTICE

Disconnect power to the frequency converter before changing switch positions.

1. Remove the LCP (local control panel) (see *Illustration 4.27*).
2. Remove any optional equipment covering the switches.
3. Set switches A53 and A54 to select the signal type. U selects voltage, I selects current.

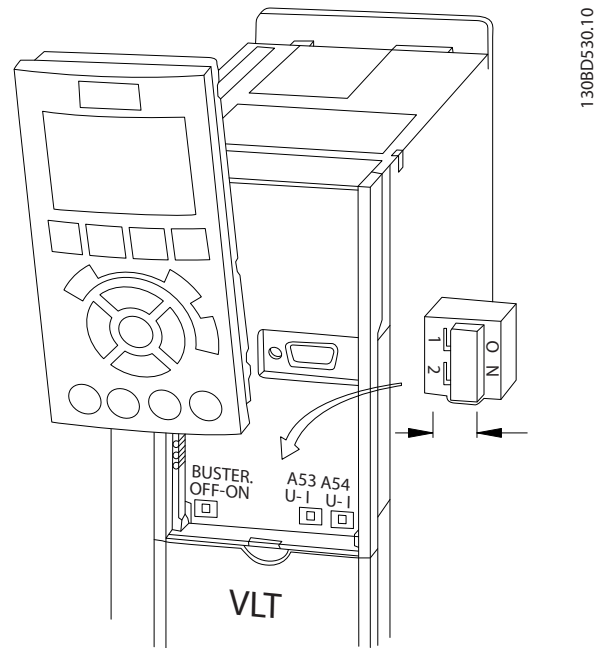

Illustration 4.27 Location of Terminal 53 and 54 Switches

4.8.5 Safe Torque Off (STO)

To run STO, extra wiring for the frequency converter is required. Refer to *VLT® Frequency Converters Safe Torque Off Operating Guide* for further information.

4.8.6 Configuring RS485 Serial Communication

RS485 is a 2-wire bus interface compatible with multi-drop network topology, and it contains the following features:

- Either Danfoss FC or Modbus RTU communication protocol, which are internal to the drive, can be used.
- Functions can be programmed remotely using the protocol software and RS485 connection or in *parameter group 8-** Communications and Options*.
- Selecting a specific communication protocol changes various default parameter settings to match the specifications of the protocol, making more protocol-specific parameters available.
- Option cards for the drive are available to provide more communication protocols. See the option card documentation for installation and operation instructions.
- A switch (BUS TER) is provided on the control card for bus termination resistance. See *Illustration 4.27*.

For basic serial communication set-up, perform the following steps:

1. Connect RS485 serial communication wiring to terminals (+)68 and (-)69.
 - 1a Use shielded serial communication cable (recommended).
 - 1b See *chapter 4.3 Grounding* for proper grounding.
2. Select the following parameter settings:
 - 2a Protocol type in *parameter 8-30 Protocol*.
 - 2b Drive address in *parameter 8-31 Address*.
 - 2c Baud rate in *parameter 8-32 Baud Rate*.

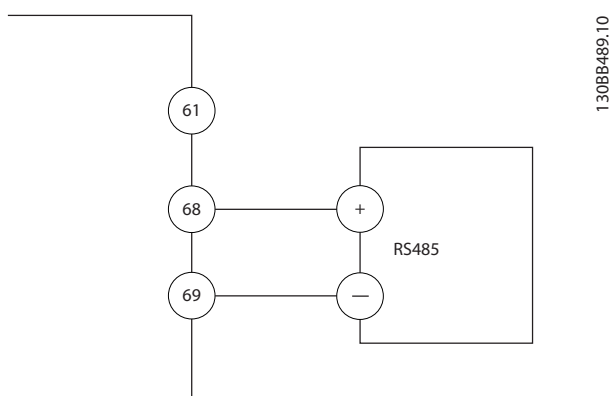

Illustration 4.28 Serial Communication Wiring Diagram

4.9 Installation Check List

Before completing installation of the unit, inspect the entire installation as detailed in *Table 4.5*. Check and mark the items when completed.

Inspect for	Description	<input checked="" type="checkbox"/>
Auxiliary equipment	<ul style="list-style-type: none"> Look for auxiliary equipment, switches, disconnects, or input fuses/circuit breakers which may reside on the input power side of the frequency converter or output side to the motor. Ensure that they are ready for full-speed operation. Check the function and installation of any sensors used for feedback to the frequency converter. Remove any power factor correction capacitors on the motor. Adjust any power factor correction capacitors on the mains side and ensure that they are dampened. 	
Cable routing	<ul style="list-style-type: none"> Ensure that the motor wiring and control wiring are separated, shielded, or in 3 separate metallic conduits for high-frequency interference isolation. 	
Control wiring	<ul style="list-style-type: none"> Check for broken or damaged wires and loose connections. Check that the control wiring is isolated from power and motor wiring for noise immunity. Check the voltage source of the signals, if necessary. <p>The use of shielded cable or twisted pair is recommended. Ensure that the shield is terminated correctly.</p>	
Cooling clearance	<ul style="list-style-type: none"> Ensure that the top and bottom clearance is adequate to ensure proper airflow for cooling, see <i>chapter 3.3 Mounting</i>. 	
Ambient conditions	<ul style="list-style-type: none"> Check that requirements for ambient conditions are met. 	
Fusing and circuit breakers	<ul style="list-style-type: none"> Check for proper fusing or circuit breakers. Check that all fuses are inserted firmly and are in operational condition and that all circuit breakers are in the open position. 	
Grounding	<ul style="list-style-type: none"> Check for sufficient ground connections and ensure that they are tight and free of oxidation. Grounding to conduit, or mounting the back panel to a metal surface, is not a suitable grounding. 	
Input and output power wiring	<ul style="list-style-type: none"> Check for loose connections. Check that the motor and mains cables are in separate conduit or separated shielded cables. 	
Panel interior	<ul style="list-style-type: none"> Inspect that the unit interior is free of dirt, metal chips, moisture, and corrosion. Check that the unit is mounted on an unpainted, metal surface. 	
Switches	<ul style="list-style-type: none"> Ensure that all switch and disconnect settings are in the proper positions. 	
Vibration	<ul style="list-style-type: none"> Check that the unit is mounted solidly, or that shock mounts are used, as necessary. Check for an unusual amount of vibration. 	

Table 4.5 Installation Check List

CAUTION

POTENTIAL HAZARD IN THE EVENT OF INTERNAL FAILURE

Risk of personal injury if the frequency converter is not properly closed.

- Before applying power, ensure that all safety covers are in place and securely fastened.

5 Commissioning

5.1 Safety Instructions

See *chapter 2 Safety* for general safety instructions.

⚠ WARNING

HIGH VOLTAGE

Frequency converters contain high voltage when connected to AC mains input power. Failure to perform installation, start-up, and maintenance by qualified personnel could result in death or serious injury.

- Installation, start-up, and maintenance must be performed by qualified personnel only.

Before applying power:

1. Verify that there is no voltage on input terminals L1 (91), L2 (92), and L3 (93), phase-to-phase, and phase-to-ground.
2. Verify that there is no voltage on output terminals 96 (U), 97 (V), and 98 (W), phase-to-phase, and phase-to-ground.
3. Confirm continuity of the motor by measuring Ω values on U-V (96–97), V-W (97–98), and W-U (98–96).
4. Check for proper grounding of the frequency converter and the motor.
5. Inspect the frequency converter for loose connections on the terminals.
6. Check that all cable glands are firmly tightened.
7. Ensure that input power to the unit is OFF and locked out. Do not rely on the frequency converter disconnect switches for input power isolation.
8. Confirm that the supply voltage matches the voltage of the frequency converter and the motor.
9. Close the door properly.

5.2 Applying Power

Apply power to the frequency converter using the following steps:

1. Confirm that the input voltage is balanced within 3%. If not, correct the input voltage imbalance before proceeding. Repeat this procedure after the voltage correction.
2. Ensure that any optional equipment wiring matches the installation application.

3. Ensure that all operator devices are in the OFF position. Close all panel doors and fasten covers securely.
4. Apply power to the unit. DO NOT start the frequency converter now. For units with a disconnect switch, turn it to the ON position to apply power to the frequency converter.

5.3 Local Control Panel Operation

5.3.1 Local Control Panel

The local control panel (LCP) is the combined display and keypad on the front of the unit.

The LCP has several user functions:

- Start, stop, and control speed when in local control.
- Show operational data, status, warnings, and cautions.
- Program frequency converter functions.
- Manually reset the frequency converter after a fault when auto reset is inactive.

An optional numeric LCP (NLCP) is also available. The NLCP operates in a manner similar to the LCP. See the product-relevant *programming guide* for details on how to use the NLCP.

NOTICE

For commissioning via PC, install the MCT 10 Set-up Software. The software is available for download (basic version) or for ordering (advanced version, ordering number 130B1000). For more information and downloads, see drives.danfoss.com/downloads/pc-tools/.

5.3.2 Start-up Message

NOTICE

During start-up, the LCP shows the message *INITIALISING*. When this message is no longer shown, the frequency converter is ready for operation. Adding or removing options can extend the duration of start-up.

5.3.3 LCP Layout

The LCP is divided into 4 functional groups (see *Illustration 5.1*).

- A. Display area.
- B. Display menu keys.
- C. Navigation keys and indicator lights (LEDs).
- D. Operation keys and reset.

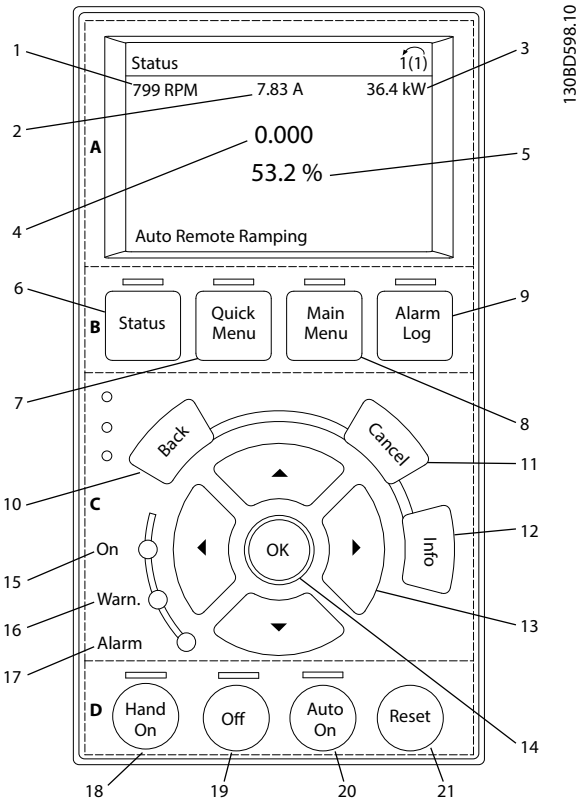

Illustration 5.1 Local Control Panel (LCP)

A. Display area

The display area is activated when the frequency converter receives power from the mains voltage, a DC bus terminal, or a 24 V DC external supply.

The information shown on the LCP can be customized for user application. Select options in the *Quick Menu Q3-13 Display Settings*.

Display	Parameter number	Default setting
1	0-20	Speed [RPM]
2	0-21	Motor Current
3	0-22	Power [kW]
4	0-23	Frequency
5	0-24	Reference [%]

Table 5.1 Legend to *Illustration 5.1*, Display Area

B. Display menu keys

Menu keys are used for menu access for parameter set-up, toggling through status display modes during normal operation, and viewing fault log data.

	Key	Function
6	Status	Shows operational information.
7	Quick Menu	Allows access to programming parameters for initial set-up instructions and many detailed application instructions.
8	Main Menu	Allows access to all programming parameters.
9	Alarm Log	Shows a list of current warnings, the last 10 alarms, and the maintenance log.

Table 5.2 Legend to *Illustration 5.1*, Display Menu Keys

C. Navigation keys and indicator lights (LEDs)

Navigation keys are used for programming functions and moving the display cursor. The navigation keys also provide speed control in local operation. There are also 3 frequency converter status indicator lights in this area.

	Key	Function
10	Back	Reverts to the previous step or list in the menu structure.
11	Cancel	Cancels the last change or command as long as the display mode has not changed.
12	Info	Press for a definition of the function being shown.
13	Navigation keys	Use the 4 navigation keys to move between items in the menu.
14	OK	Use to access parameter groups or to enable a selection.

Table 5.3 Legend to *Illustration 5.1*, Navigation Keys

	Indicator	LED	Function
15	On	Green	The ON LED activates when the frequency converter receives power from the mains voltage, a DC bus terminal, or a 24 V external supply.
16	Warn	Yellow	When warning conditions are met, the yellow WARN LED comes on and text appears in the display area identifying the problem.
17	Alarm	Red	A fault condition causes the red alarm LED to flash and an alarm text is shown.

Table 5.4 Legend to *Illustration 5.1*, Indicator Lights (LEDs)

D. Operation keys and reset

Operation keys are at the bottom of the LCP.

	Key	Function
18	Hand On	Starts the frequency converter in local control. <ul style="list-style-type: none"> An external stop signal by control input or serial communication overrides the local hand on.
19	Off	Stops the motor but does not remove power to the frequency converter.
20	Auto On	Puts the system in remote operational mode. <ul style="list-style-type: none"> Responds to an external start command by control terminals or serial communication.
21	Reset	Resets the frequency converter manually after a fault has been cleared.

Table 5.5 Legend to *Illustration 5.1, Operation Keys and Reset*

NOTICE

The display contrast can be adjusted by pressing [Status] and the [▲]/[▼] keys.

5.3.4 Parameter Settings

Establishing the correct programming for applications often requires setting functions in several related parameters. Parameter details are provided in *chapter 9.2 Parameter Menu Structure*.

Programming data is stored internally in the frequency converter.

- For back-up, upload data to the LCP memory.
- To download data to another frequency converter, connect the LCP to that unit and download the stored settings.
- Restoring factory default settings does not change data stored in the LCP memory.

5.3.5 Uploading/Downloading Data to/from the LCP

- Press [Off] to stop the motor before uploading or downloading data.
- Press [Main Menu], *parameter 0-50 LCP Copy* and press [OK].
- Select [1] *All to LCP* to upload data to the LCP, or select [2] *All from LCP* to download data from the LCP.
- Press [OK]. A progress bar shows the uploading or downloading progress.
- Press [Hand On] or [Auto On] to return to normal operation.

5.3.6 Changing Parameter Settings

Parameter settings can be accessed and changed from the *Quick Menu* or from the *Main Menu*. The *Quick Menu* only gives access to a limited number of parameters.

- Press [Quick Menu] or [Main Menu] on the LCP.
- Press [▲] [▼] to browse through the parameter groups.
- Press [OK] to select a parameter group.
- Press [▲] [▼] to browse through the parameters.
- Press [OK] to select a parameter.
- Press [▲] [▼] to change the value of a parameter setting.
- Press [◀] [▶] to shift digit when a decimal parameter is in the editing state.
- Press [OK] to accept the change.
- Press either [Back] twice to enter *Status*, or press [Main Menu] once to enter the *Main Menu*.

View changes

Quick Menu Q5 - Changes Made lists all parameters changed from default settings.

- The list only shows parameters which have been changed in the current edit set-up.
- Parameters which have been reset to default values are not listed.
- The message *Empty* indicates that no parameters have been changed.

5.3.7 Restoring Default Settings

NOTICE

Risk of losing programming, motor data, localization, and monitoring records by restoration of default settings. To provide a back-up, upload data to the LCP before initialization.

Restoring the default parameter settings is done by initialization of the frequency converter. Initialization is carried out through *parameter 14-22 Operation Mode* (recommended) or manually.

- Initialization using *parameter 14-22 Operation Mode* does not reset frequency converter settings, such as hours run, serial communication selections, personal menu settings, fault log, alarm log, and other monitoring functions.
- Manual initialization erases all motor, programming, localization, and monitoring data and restores factory default settings.

Recommended initialization procedure via parameter 14-22 Operation Mode

1. Press [Main Menu] twice to access parameters.
2. Scroll to *parameter 14-22 Operation Mode* and press [OK].
3. Scroll to [2] *Initialisation* and press [OK].
4. Remove power to the unit and wait for the display to turn off.
5. Apply power to the unit.

Default parameter settings are restored during start-up. The restore may take slightly longer than normal.

1. *Alarm 80, Drive initialised* is shown.
2. Press [Reset] to return to operating mode.

Manual initialization procedure

1. Remove power to the unit and wait for the display to turn off.
2. Press and hold [Status], [Main Menu], and [OK] at the same time while applying power to the unit. Press the keys for approximately 5 s, or until a click is heard and the fan starts.

Factory default parameter settings are restored during start-up. The restore may take slightly longer than normal.

Manual initialization does not reset the following frequency converter information:

- *Parameter 15-00 Operating hours*
- *Parameter 15-03 Power Up's*
- *Parameter 15-04 Over Temp's*
- *Parameter 15-05 Over Volt's*

5.4 Basic Programming

5.4.1 Commissioning with SmartStart

The SmartStart wizard enables fast configuration of basic motor and application parameters.

- SmartStart starts automatically at first power-up or after initialization of the frequency converter.
- Follow the on-screen instructions to complete the commissioning of the frequency converter. Always reactivate SmartStart by selecting *Quick Menu Q4 - SmartStart*.
- For commissioning without use of the SmartStart wizard, refer to *chapter 5.4.2 Commissioning via [Main Menu]* or the *programming guide*.

NOTICE

Motor data is required for the SmartStart set-up. The required data is normally available on the motor nameplate.

5.4.2 Commissioning via [Main Menu]

Recommended parameter settings are intended for start-up and check-out purposes. Application settings may vary.

Enter data with power ON, but before operating the frequency converter.

1. Press [Main Menu] on the LCP.
2. Press the navigation keys to scroll to *parameter group 0-** Operation/Display* and press [OK].

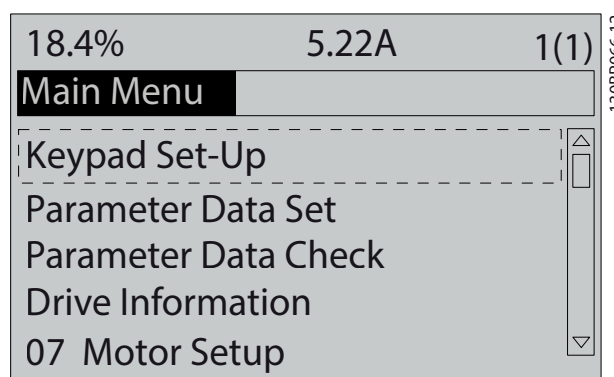

Illustration 5.2 Main Menu

3. Press the navigation keys to scroll to *parameter group 0-0* Basic Settings* and press [OK].

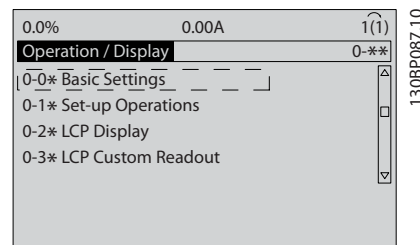

Illustration 5.3 Operation/Display

4. Press the navigation keys to scroll to *parameter 0-03 Regional Settings* and press [OK].

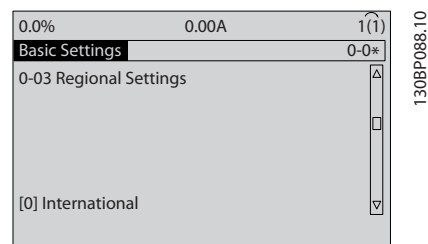

Illustration 5.4 Basic Settings

5. Press the navigation keys to select [0] *International* or [1] *North America* as appropriate and press [OK]. (This selection changes the default settings for several basic parameters).
6. Press [Main Menu] on the LCP.
7. Press the navigation keys to scroll to *parameter 0-01 Language*.
8. Select the language and press [OK].
9. If a jumper wire is in place between control terminals 12 and 27, leave *parameter 5-12 Terminal 27 Digital Input* at factory default. Otherwise, select [0] *No operation* in *parameter 5-12 Terminal 27 Digital Input*.
10. Make the application-specific settings in the following parameters:
 - 10a *Parameter 3-02 Minimum Reference*.
 - 10b *Parameter 3-03 Maximum Reference*.
 - 10c *Parameter 3-41 Ramp 1 Ramp Up Time*.
 - 10d *Parameter 3-42 Ramp 1 Ramp Down Time*.
 - 10e *Parameter 3-13 Reference Site*. Linked to Hand/Auto Local Remote.

5.5 Checking Motor Rotation

The direction of rotation can be changed by switching 2 phases in the motor cable, or by changing the setting of *parameter 4-10 Motor Speed Direction*.

- Terminal U/T1/96 connected to U-phase.
- Terminal V/T2/97 connected to V-phase.
- Terminal W/T3/98 connected to W-phase.

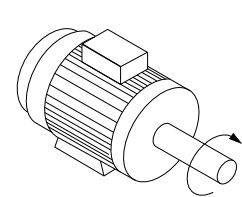
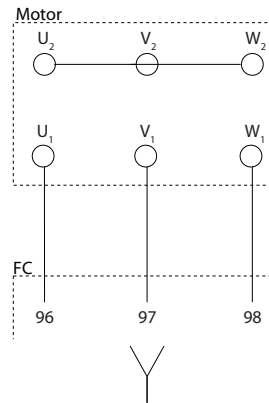

5

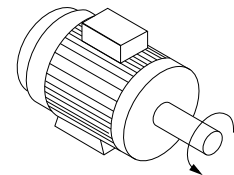
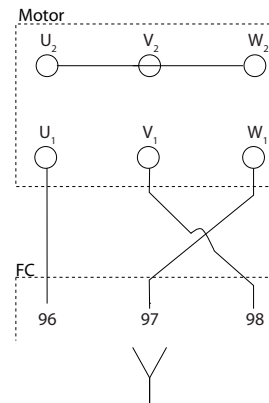

Illustration 5.5 Wiring for Changing Motor Direction

Perform a motor rotation check using *parameter 1-28 Motor Rotation Check* and follow the steps shown in the display.

5.6 Local-control Test

1. Press [Hand On] to provide a local start command to the frequency converter.
2. Press [▲] to accelerate the frequency converter to full speed. Moving the cursor left of the decimal point provides quicker input changes.
3. Note any acceleration problems.
4. Press [Off]. Note any deceleration problems.

If acceleration or deceleration problems occur, see *chapter 7.7 Troubleshooting*. See *chapter 7.6 List of Warnings and Alarms* for resetting the frequency converter after a trip.

5

5.7 System Start-up

The procedure in this section requires user-wiring and application programming to be completed. The following procedure is recommended after application set-up is completed.

1. Press [Auto On].
2. Apply an external run command.
3. Adjust the speed reference throughout the speed range.
4. Remove the external run command.
5. Check the sound and vibration levels of the motor to ensure that the system is working as intended.

If warnings or alarms occur, see *chapter 7.6 List of Warnings and Alarms*.

6 Application Set-up Examples

6.1 Introduction

The examples in this section are intended as a quick reference for common applications.

- Parameter settings are the regional default values unless otherwise indicated (selected in *parameter 0-03 Regional Settings*).
- Parameters associated with the terminals and their settings are shown next to the drawings.
- Where switch settings for analog terminals A53 or A54 are required, these settings are also shown.

NOTICE

When the optional STO feature is used, a jumper wire may be required between terminal 12 (or 13) and terminal 37 for the frequency converter to operate with factory default programming values.

6.2 Application Examples

6.2.1 Automatic Motor Adaptation (AMA)

		Parameters	
FC		Function	Setting
+24 V	12	Parameter 1-29 Automatic Motor Adaptation (AMA)	[1] Enable complete AMA
+24 V	13		
D IN	18		
D IN	19		
COM	20	Parameter 5-12 Terminal 27 Digital Input	[2]* Coast inverse
D IN	27		
D IN	29		
D IN	32		
D IN	33	* = Default value	
Notes/comments:			
Parameter group 1-2* Motor Data must be set according to motor.			
D IN 37 is an option.			
+10 V	50		
A IN	53		
A IN	54		
COM	55		
A OUT	42		
COM	39		

Table 6.1 AMA with T27 Connected

		Parameters	
FC		Function	Setting
+24 V	12	Parameter 1-29 Automatic Motor Adaptation (AMA)	[1] Enable complete AMA
+24 V	13		
D IN	18		
D IN	19		
COM	20	Parameter 5-12 Terminal 27 Digital Input	[0] No operation
D IN	27		
D IN	29		
D IN	32		
D IN	33	* = Default value	
Notes/comments:			
Parameter group 1-2* Motor Data must be set according to motor.			
D IN 37 is an option.			
+10 V	50		
A IN	53		
A IN	54		
COM	55		
A OUT	42		
COM	39		

Table 6.2 AMA without T27 Connected

6.2.2 Speed

		Parameters	
FC		Function	Setting
+24 V	12	Parameter 6-10 Terminal 53 Low Voltage	0.07 V*
+24 V	13		
D IN	18		
D IN	19		
COM	20	Parameter 6-11 Terminal 53 High Voltage	10 V*
D IN	27		
D IN	29		
D IN	32		
D IN	33	Parameter 6-14 Terminal 53 Low Ref./Feedb. Value	0 Hz
D IN	37		
+10 V	50		
A IN	53		
A IN	54	Parameter 6-15 Terminal 53 High Ref./Feedb. Value	50 Hz
COM	55		
A OUT	42		
COM	39		
* = Default value			
Notes/comments:			
D IN 37 is an option.			

Table 6.3 Analog Speed Reference (Voltage)

6

FC		Parameters		
		Function	Setting	
+24 V	12	130BB927.10 	Parameter 6-12 Terminal 53 Low Current	4 mA*
+24 V	13		Parameter 6-13 Terminal 53 High Current	20 mA*
D IN	18		Parameter 6-14 Terminal 53 Low Ref./Feedb. Value	0 Hz
D IN	19		Parameter 6-15 Terminal 53 High Ref./Feedb. Value	50 Hz
COM	20		* = Default value	
D IN	27		Notes/comments: D IN 37 is an option.	
D IN	29			
D IN	32			
D IN	33			
D IN	37			
+10 V	50			
A IN	53			
A IN	54			
COM	55			
A OUT	42			
COM	39			
U - I				
A53				

Table 6.4 Analog Speed Reference (Current)

FC		Parameters		
		Function	Setting	
+24 V	12	130BB804.11 	Parameter 5-10 Terminal 18 Digital Input	[8]* Start
+24 V	13		Parameter 5-12 Terminal 27 Digital Input	[19] Freeze Reference
D IN	18		Parameter 5-13 Terminal 29 Digital Input	[21] Speed Up
D IN	19		Parameter 5-14 Terminal 32 Digital Input	[22] Speed Down
COM	20		* = Default value	
D IN	27		Notes/comments: D IN 37 is an option.	
D IN	29			
D IN	32			
D IN	33			
D IN	37			
+10 V	50			
A IN	53			
A IN	54			
COM	55			
A OUT	42			
COM	39			
U - I				
A53				

Table 6.6 Speed Up/Down

FC		Parameters		
		Function	Setting	
+24 V	12	130BB663.10 	Parameter 6-10 Terminal 53 Low Voltage	0.07 V*
+24 V	13		Parameter 6-11 Terminal 53 High Voltage	10 V*
D IN	18		Parameter 6-14 Terminal 53 Low Ref./Feedb. Value	0 Hz
D IN	19		Parameter 6-15 Terminal 53 High Ref./Feedb. Value	1500 Hz
COM	20		* = Default value	
D IN	27		Notes/comments: D IN 37 is an option.	
D IN	29			
D IN	32			
D IN	33			
D IN	37			
+10 V	50			
A IN	53			
A IN	54			
COM	55			
A OUT	42			
COM	39			
U - I				
A53				

Table 6.5 Speed Reference (Using a Manual Potentiometer)

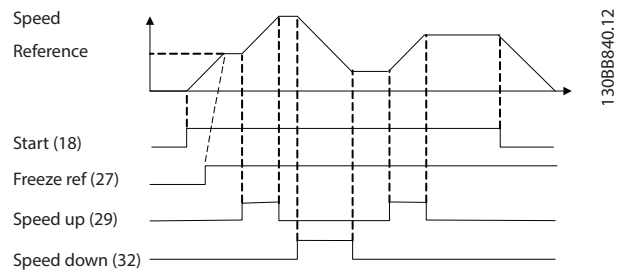

Illustration 6.1 Speed Up/Down

6.2.3 Start/Stop

		Parameters	
FC		Function	Setting
+24 V	12	Parameter 5-10 Terminal 18 Digital Input	[8]* Start
+24 V	13		
D IN	18	Parameter 5-12 Terminal 27 Digital Input	[0] No operation
D IN	19		
COM	20	Parameter 5-19 Terminal 37 Safe Stop	[1] Safe Alarm
D IN	27		
D IN	29	* = Default value	
D IN	32		
D IN	33	Notes/comments: If parameter 5-12 Terminal 27 Digital Input is set to [0] No operation, a jumper wire to terminal 27 is not needed. D IN 37 is an option.	
D IN	37		
+10	50		
A IN	53		
A IN	54		
COM	55		
A OUT	42		
COM	39		

Table 6.7 Start/Stop Command with STO

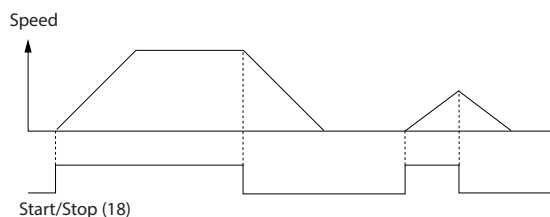

Illustration 6.2 Start/Stop Command with STO

		Parameters	
FC		Function	Setting
+24 V	12	Parameter 5-10 Terminal 18 Digital Input	[9] Latched Start
+24 V	13		
D IN	18	Parameter 5-12 Terminal 27 Digital Input	[6] Stop Inverse
D IN	19		
COM	20	* = Default value	
D IN	27		
D IN	29	Notes/comments: If parameter 5-12 Terminal 27 Digital Input is set to [0] No operation, a jumper wire to terminal 27 is not needed. D IN 37 is an option.	
D IN	32		
D IN	33		
D IN	37		
+10 V	50		
A IN	53		
A IN	54		
COM	55		
A OUT	42		
COM	39		

Table 6.8 Pulse Start/Stop

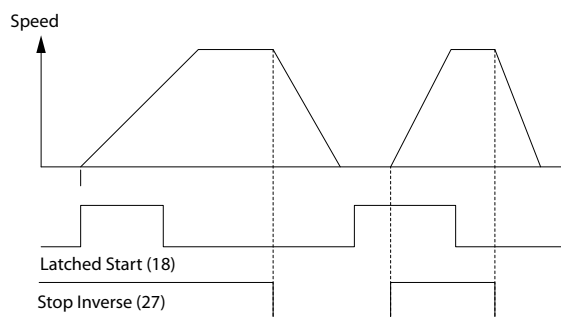

Illustration 6.3 Latched Start/Stop Inverse

6

		Parameters	
FC		Function	Setting
+24 V	12	Parameter 5-10 Terminal 18 Digital Input	[8] Start
+24 V	13		
D IN	18	Parameter 5-11 Terminal 19 Digital Input	[10]*
D IN	19		
COM	20	Parameter 5-12 Terminal 27 Digital Input	[0] No operation
D IN	27		
D IN	29	Parameter 5-14 Terminal 32 Digital Input	[16] Preset ref bit 0
D IN	32		
D IN	33	Parameter 5-15 Terminal 33 Digital Input	[17] Preset ref bit 1
+10 V	50		
A IN	53	Parameter 3-10 Preset Reference	Preset ref. 0
A IN	54		Preset ref. 1
COM	55		Preset ref. 2
A OUT	42		Preset ref. 3
COM	39	* = Default value	
		Notes/comments: D IN 37 is an option.	

Table 6.9 Start/Stop with Reversing and 4 Preset Speeds

6.2.4 External Alarm Reset

		Parameters	
FC		Function	Setting
+24 V	12	Parameter 5-11 Terminal 19 Digital Input	[1] Reset
+24 V	13		
D IN	18	* = Default value	
D IN	19	Notes/comments: D IN 37 is an option.	
COM	20		
D IN	27		
D IN	29		
D IN	32		
D IN	33		
D IN	37		
+10 V	50		
A IN	53		
A IN	54		
COM	55		
A OUT	42		
COM	39		

Table 6.10 External Alarm Reset

6.2.5 RS485

		Parameters	
		Function	Setting
		Parameter 8-30 Protocol	FC*
		Parameter 8-31 Address	1*
		Parameter 8-32 Baud Rate	9600*
		* = Default value	
Notes/comments: Select protocol, address, and baud rate in these parameters. D IN 37 is an option.			

Table 6.11 RS485 Network Connection

6.2.6 Motor Thermistor

WARNING

THERMISTOR INSULATION

Risk of personal injury or equipment damage.

- Use only thermistors with reinforced or double insulation to meet PELV insulation requirements.

		Parameters	
		Function	Setting
		Parameter 1-90 Motor Thermal Protection	[2] Thermistor trip
		Parameter 1-93 Thermistor Source	[1] Analog input 53
		* = Default value	
		Notes/comments: If only a warning is desired, set parameter parameter 1-90 Motor Thermal Protection to [1] Thermistor warning. D IN 37 is an option.	

Table 6.12 Motor Thermistor

7 Maintenance, Diagnostics, and Troubleshooting

7.1 Introduction

This chapter includes:

- Maintenance and service guidelines.
- Status messages.
- Warnings and alarms.
- Basic troubleshooting.

7.2 Maintenance and Service

Under normal operating conditions and load profiles, the frequency converter is maintenance-free throughout its designed lifetime. To prevent breakdown, danger, and damage, examine the frequency converter at regular intervals depending on the operating conditions. Replace worn or damaged parts with original spare parts or standard parts. For service and support, refer to www.danfoss.com/contact/sales_and_services/.

⚠ WARNING

UNINTENDED START

When the frequency converter is connected to AC mains, DC supply, or load sharing, the motor can start at any time. Unintended start during programming, service, or repair work can result in death, serious injury, or property damage. The motor can start with an external switch, a fieldbus command, an input reference signal from the LCP or LOP, via remote operation using MCT 10 Set-up Software, or after a cleared fault condition.

To prevent unintended motor start:

- Press [Off/Reset] on the LCP before programming parameters.
- Disconnect the frequency converter from the mains.
- Completely wire and assemble the frequency converter, motor, and any driven equipment before connecting the frequency converter to AC mains, DC supply, or load sharing.

7.3 Heat Sink Access Panel

7.3.1 Removing the Heat Sink Access Panel

The frequency converter has an optional access panel for accessing the heat sink.

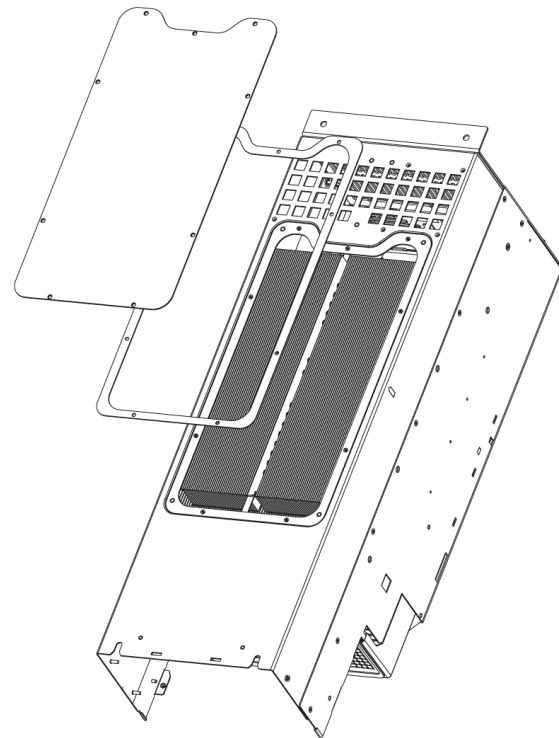

Illustration 7.1 Heat Sink Access Panel

1. Do not run the frequency converter while removing the heat sink access panel.
2. If the frequency converter is mounted on a wall, or its back is otherwise inaccessible, reposition it to provide full access.
3. Remove the screws (3 mm (0.12 in) internal hex) connecting the access panel to the back of the enclosure. There are 5 or 9 screws depending on the size of the frequency converter.

Reinstall in reverse order of this procedure and tighten fasteners according to *chapter 8.8 Connection Tightening Torques*.

7.4 Status Messages

When the frequency converter is in status mode, status messages are generated automatically and appear in the bottom line of the display (see *Illustration 7.2*).

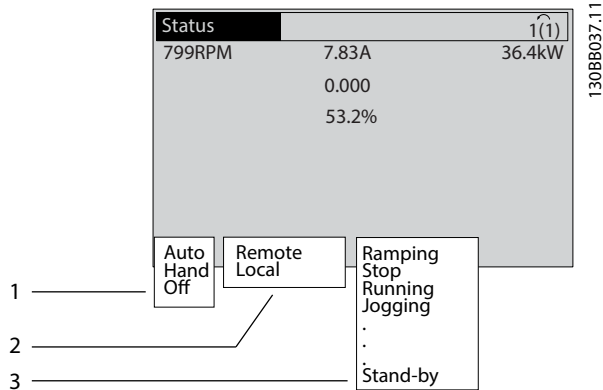

1	Operating mode (see <i>Table 7.1</i>)
2	Reference site (see <i>Table 7.2</i>)
3	Operation status (see <i>Table 7.3</i>)

Illustration 7.2 Status Display

Table 7.1 to *Table 7.3* describe the status messages shown.

Off	The frequency converter does not react to any control signal until [Auto On] or [Hand On] is pressed.
Auto On	The frequency converter is controlled from the control terminals and/or the serial communication.
Hand On	Use the navigation keys on the LCP to control the frequency converter. Stop commands, reset, reversing, DC brake, and other signals applied to the control terminals override local control.

Table 7.1 Operating Mode

Remote	The speed reference is given from external signals, serial communication, or internal preset references.
Local	The frequency converter uses [Hand On] control or reference values from the LCP.

Table 7.2 Reference Site

AC Brake	<i>Parameter 2-16 AC brake Max. Current</i> was selected in <i>parameter 2-10 Brake Function</i> . The AC brake overmagnetizes the motor to achieve a controlled slow-down.
AMA finish OK	Automatic motor adaptation (AMA) was carried out successfully.
AMA ready	AMA is ready to start. Press [Hand On] to start.
AMA running	AMA process is in progress.
Braking	The brake chopper is in operation. Generative energy is absorbed by the brake resistor.
Braking max.	The brake chopper is in operation. The power limit for the brake resistor defined in <i>parameter 2-12 Brake Power Limit (kW)</i> has been reached.
Coast	<ul style="list-style-type: none"> Coast inverse was selected as a function for a digital input (<i>parameter group 5-1* Digital Inputs</i>). The corresponding terminal is not connected. Coast activated by serial communication.
Ctrl. ramp-down	<p>[1] <i>Control ramp-down</i> was selected in <i>parameter 14-10 Mains Failure</i>.</p> <ul style="list-style-type: none"> The mains voltage is below the value set in <i>parameter 14-11 Mains Voltage at Mains Fault</i> at mains fault. The frequency converter ramps down the motor using a controlled ramp down.
Current High	The frequency converter output current is above the limit set in <i>parameter 4-51 Warning Current High</i> .
Current Low	The frequency converter output current is below the limit set in <i>parameter 4-52 Warning Speed Low</i> .
DC Hold	[1] <i>DC hold</i> is selected in <i>parameter 1-80 Function at Stop</i> and a stop command is active. The motor is held by a DC current set in <i>parameter 2-00 DC Hold/Preheat Current</i> .
DC Stop	<p>The motor is held with a DC current (<i>parameter 2-01 DC Brake Current</i>) for a specified time (<i>parameter 2-02 DC Braking Time</i>).</p> <ul style="list-style-type: none"> The DC brake cut-in speed is reached in <i>parameter 2-03 DC Brake Cut In Speed [RPM]</i>, and a stop command is active. DC brake (inverse) is selected as a function for a digital input (<i>parameter group 5-1* Digital Inputs</i>). The corresponding terminal is not active. The DC brake is activated via serial communication.
Feedback high	The sum of all active feedbacks is above the feedback limit set in <i>parameter 4-57 Warning Feedback High</i> .

Feedback low	The sum of all active feedbacks is below the feedback limit set in <i>parameter 4-56 Warning Feedback Low</i> .
Freeze output	The remote reference, which holds the present speed, is active. <ul style="list-style-type: none"> Freeze output was selected as a function for a digital input (<i>parameter group 5-1* Digital Inputs</i>). The corresponding terminal is active. Speed control is only possible via the terminal functions speed up and speed down. Hold ramp is activated via serial communication.
Freeze output request	A freeze output command was given, but the motor remains stopped until a run permissive signal is received.
Freeze ref.	Freeze reference was selected as a function for a digital input (<i>parameter group 5-1* Digital Inputs</i>). The corresponding terminal is active. The frequency converter saves the actual reference. Changing the reference is now only possible via terminal functions speed up and speed down.
Jog request	A jog command was given, but the motor remains stopped until a run permissive signal is received via a digital input.
Jogging	The motor runs as programmed in <i>parameter 3-19 Jog Speed [RPM]</i> . <ul style="list-style-type: none"> Jog was selected as a function for a digital input (<i>parameter group 5-1* Digital Inputs</i>). The corresponding terminal (for example terminal 29) is active. The jog function is activated via the serial communication. The jog function was selected as a reaction for a monitoring function (for example No signal). The monitoring function is active.
Motor check	In <i>parameter 1-80 Function at Stop, [2] Motor check</i> was selected. A stop command is active. To ensure that a motor is connected to the frequency converter, a permanent test current is applied to the motor.
OVC control	Overvoltage control was activated in <i>parameter 2-17 Over-voltage Control, [2] Enabled</i> . The connected motor supplies the frequency converter with generative energy. The overvoltage control adjusts the V/Hz ratio to run the motor in controlled mode and to prevent the frequency converter from tripping.
PowerUnit Off	(Only frequency converters with a 24 V external supply installed). Mains supply to the frequency converter was removed, and the control card is supplied by the external 24 V.

Protection md	Protection mode is active. The unit has detected a critical status (overcurrent or overvoltage). <ul style="list-style-type: none"> To avoid tripping, switching frequency is reduced to 4 kHz. If possible, protection mode ends after approximately 10 s. Protection mode can be restricted in <i>parameter 14-26 Trip Delay at Inverter Fault</i>.
Qstop	The motor is decelerating using <i>parameter 3-81 Quick Stop Ramp Time</i> . <ul style="list-style-type: none"> Quick stop inverse was selected as a function for a digital input (<i>parameter group 5-1* Digital Inputs</i>). The corresponding terminal is not active. The quick stop function was activated via serial communication.
Ramping	The motor is accelerating/decelerating using the active ramp up/down. The reference, a limit value, or a standstill is not yet reached.
Ref. high	The sum of all active references is above the reference limit set in <i>parameter 4-55 Warning Reference High</i> .
Ref. low	The sum of all active references is below the reference limit set in <i>parameter 4-54 Warning Reference Low</i> .
Run on ref.	The frequency converter is running in the reference range. The feedback value matches the setpoint value.
Run request	A start command was given, but the motor remains stopped until a run permissive signal is received via digital input.
Running	The frequency converter drives the motor.
Sleep Mode	The energy-saving function is enabled. The motor has stopped, but restarts automatically when required.
Speed high	Motor speed is above the value set in <i>parameter 4-53 Warning Speed High</i> .
Speed low	Motor speed is below the value set in <i>parameter 4-52 Warning Speed Low</i> .
Standby	In auto-on mode, the frequency converter starts the motor with a start signal from a digital input or serial communication.
Start delay	In <i>parameter 1-71 Start Delay</i> , a delay starting time was set. A start command is activated and the motor starts after the start delay time expires.
Start fwd/rev	Start forward and start reverse were selected as functions for 2 different digital inputs (<i>parameter group 5-1* Digital Inputs</i>). The motor starts in forward or reverse direction depending on which corresponding terminal is activated.

Stop	The frequency converter has received a stop command from the LCP, digital input, or serial communication.
Trip	An alarm occurred and the motor is stopped. Once the alarm is cleared, the frequency converter can be reset manually by pressing [Reset], or remotely by control terminals or serial communication.
Trip lock	An alarm occurred and the motor is stopped. Once the alarm is cleared, cycle power to the frequency converter. The frequency converter can then be reset manually by pressing [Reset], or remotely by control terminals or serial communication.

Table 7.3 Operation Status

NOTICE

In auto/remote mode, the frequency converter requires external commands to execute functions.

7.5 Warning and Alarm Types

Warnings

A warning is issued when an alarm condition is impending or when an abnormal operating condition is present. The warning may result in the frequency converter issuing an alarm. A warning clears itself when the abnormal condition ceases.

Alarms

An alarm indicates a fault that requires immediate attention. The fault always triggers a trip or a trip lock. Reset the system after an alarm.

Trip

An alarm is issued when the frequency converter is tripped, meaning that the frequency converter suspends operation to prevent frequency converter or system damage. The motor coasts to a stop. The frequency converter logic continues to operate and monitor the frequency converter status. After the fault condition is remedied, the frequency converter can be reset. It is then ready to restart operation.

Resetting the frequency converter after trip/trip lock

A trip can be reset in any of 4 ways:

- Press [Reset] on the LCP.
- Digital reset input command.
- Serial communication reset input command.
- Auto reset.

Trip lock

Input power is cycled. The motor coasts to a stop. The frequency converter continues to monitor the frequency converter status.

1. Remove input power to the frequency converter.
 2. Correct the cause of the fault.
 3. Reset the frequency converter.
- A warning is shown in the LCP along with the warning number.
 - An alarm flashes along with the alarm number.

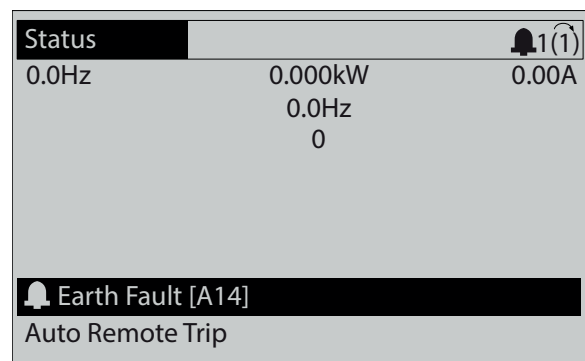
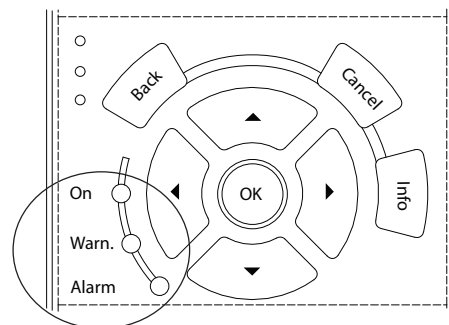

Illustration 7.3 Alarm Display Example

In addition to the text and alarm code in the LCP, there are 3 status indicator lights (LEDs).



	Warning LED	Alarm LED
Warning	On	Off
Alarm	Off	On (flashing)
Trip lock	On	On (flashing)

Illustration 7.4 Status Indicator Lights (LEDs)

7.6 List of Warnings and Alarms

The following warning and alarm information defines each warning or alarm condition, provides the probable cause for the condition, and details a remedy or troubleshooting procedure.

WARNING 1, 10 Volts low

The control card voltage is less than 10 V from terminal 50. Remove some of the load from terminal 50, as the 10 V supply is overloaded. Maximum 15 mA or minimum 590 Ω.

A short circuit in a connected potentiometer or incorrect wiring of the potentiometer can cause this condition.

Troubleshooting

- Remove the wiring from terminal 50. If the warning clears, the problem is with the wiring. If the warning does not clear, replace the control card.

WARNING/ALARM 2, Live zero error

This warning or alarm only appears if programmed in *parameter 6-01 Live Zero Timeout Function*. The signal on 1 of the analog inputs is less than 50% of the minimum value programmed for that input. Broken wiring or a faulty device sending the signal can cause this condition.

Troubleshooting

- Check connections on all analog mains terminals.
 - Control card terminals 53 and 54 for signals, terminal 55 common.
 - VLT® General Purpose I/O MCB 101 terminals 11 and 12 for signals, terminal 10 common.
 - VLT® Analog I/O Option MCB 109 terminals 1, 3, and 5 for signals, terminals 2, 4, and 6 common.
- Check that the drive programming and switch settings match the analog signal type.
- Perform an input terminal signal test.

WARNING/ALARM 3, No motor

No motor is connected to the output of the frequency converter.

WARNING/ALARM 4, Mains phase loss

A phase is missing on the supply side, or the mains voltage imbalance is too high. This message also appears for a fault in the input rectifier. Options are programmed in *parameter 14-12 Function at Mains Imbalance*.

Troubleshooting

- Check the supply voltage and supply currents to the frequency converter.

WARNING 5, DC link voltage high

The DC-link voltage (DC) is higher than the high-voltage warning limit. The limit depends on the drive voltage rating. The unit is still active.

WARNING 6, DC link voltage low

The DC-link voltage (DC) is lower than the low voltage warning limit. The limit depends on the drive voltage rating. The unit is still active.

WARNING/ALARM 7, DC overvoltage

If the DC-link voltage exceeds the limit, the frequency converter trips after a certain time.

Troubleshooting

- Connect a brake resistor.
- Extend the ramp time.
- Change the ramp type.
- Activate the functions in *parameter 2-10 Brake Function*.
- Increase *parameter 14-26 Trip Delay at Inverter Fault*.
- If the alarm/warning occurs during a power sag, use kinetic back-up (*parameter 14-10 Mains Failure*).

WARNING/ALARM 8, DC under voltage

If the DC-link voltage drops below the undervoltage limit, the drive checks for 24 V DC back-up supply. If no 24 V DC back-up supply is connected, the drive trips after a fixed time delay. The time delay varies with unit size.

Troubleshooting

- Check that the supply voltage matches the drive voltage.
- Perform an input voltage test.
- Perform a soft-charge circuit test.

WARNING/ALARM 9, Inverter overload

The frequency converter has run with more than 100% overload for too long and is about to cut out. The counter for electronic thermal inverter protection issues a warning at 98% and trips at 100% with an alarm. The frequency converter cannot be reset until the counter is below 90%.

Troubleshooting

- Compare the output current shown on the LCP with the frequency converter rated current.
- Compare the output current shown on the LCP with the measured motor current.
- Show the thermal frequency converter load on the LCP and monitor the value. When running above the frequency converter continuous current rating, the counter increases. When running below the frequency converter continuous current rating, the counter decreases.

WARNING/ALARM 10, Motor overload temperature

According to the electronic thermal protection (ETR), the motor is too hot.

Select 1 of these options:

- The frequency converter issues a warning or an alarm when the counter is >90% if *parameter 1-90 Motor Thermal Protection* is set to warning options.
- The frequency converter trips when the counter reaches 100% if *parameter 1-90 Motor Thermal Protection* is set to trip options.

The fault occurs when the motor runs with more than 100% overload for too long.

Troubleshooting

- Check for motor overheating.
- Check if the motor is mechanically overloaded.
- Check that the motor current set in *parameter 1-24 Motor Current* is correct.
- Ensure that the motor data in *parameters 1-20 to 1-25* is set correctly.
- If an external fan is in use, check that it is selected in *parameter 1-91 Motor External Fan*.
- Running AMA in *parameter 1-29 Automatic Motor Adaptation (AMA)* tunes the frequency converter to the motor more accurately and reduces thermal loading.

WARNING/ALARM 11, Motor thermistor overtemp

Check whether the thermistor is disconnected. Select whether the frequency converter issues a warning or an alarm in *parameter 1-90 Motor Thermal Protection*.

Troubleshooting

- Check for motor overheating.
- Check if the motor is mechanically overloaded.
- When using terminal 53 or 54, check that the thermistor is connected correctly between either terminal 53 or 54 (analog voltage input) and terminal 50 (+10 V supply). Also check that the terminal switch for 53 or 54 is set for voltage. Check that *parameter 1-93 Thermistor Source* selects terminal 53 or 54.
- When using terminal 18, 19, 31, 32, or 33 (digital inputs), check that the thermistor is connected correctly between the digital input terminal used (digital input PNP only) and terminal 50. Select the terminal to use in *parameter 1-93 Thermistor Source*.

WARNING/ALARM 12, Torque limit

The torque has exceeded the value in *parameter 4-16 Torque Limit Motor Mode* or the value in *parameter 4-17 Torque Limit Generator Mode*. *Parameter 14-25 Trip Delay at Torque Limit* can change this

warning from a warning-only condition to a warning followed by an alarm.

Troubleshooting

- If the motor torque limit is exceeded during ramp-up, extend the ramp-up time.
- If the generator torque limit is exceeded during ramp-down, extend the ramp-down time.
- If torque limit occurs while running, increase the torque limit. Make sure that the system can operate safely at a higher torque.
- Check the application for excessive current draw on the motor.

WARNING/ALARM 13, Over current

The inverter peak current limit (approximately 200% of the rated current) is exceeded. The warning lasts approximately 1.5 s, then the frequency converter trips and issues an alarm. Shock loading or quick acceleration with high-inertia loads can cause this fault. If the acceleration during ramp-up is quick, the fault can also appear after kinetic back-up. If extended mechanical brake control is selected, a trip can be reset externally.

Troubleshooting

- Remove the power and check if the motor shaft can be turned.
- Check that the motor size matches the frequency converter.
- Check that the motor data is correct in *parameters 1-20 to 1-25*.

ALARM 14, Earth (ground) fault

There is current from the output phase to ground, either in the cable between the frequency converter and the motor, or in the motor itself. The current transducers detect the ground fault by measuring current going out from the frequency converter and current going into the frequency converter from the motor. Ground fault is issued if the deviation of the 2 currents is too large. The current going out of the frequency converter must be the same as the current going into the frequency converter.

Troubleshooting

- Remove power to the frequency converter and repair the ground fault.
- Check for ground faults in the motor by measuring the resistance to ground of the motor cables and the motor with a megohmmeter.
- Reset any potential individual offset in the 3 current transducers in the frequency converter. Perform the manual initialization or perform a complete AMA. This method is most relevant after changing the power card.

ALARM 15, Hardware mismatch

A fitted option is not operational with the present control card hardware or software.

Record the value of the following parameters and contact Danfoss.

- *Parameter 15-40 FC Type.*
- *Parameter 15-41 Power Section.*
- *Parameter 15-42 Voltage.*
- *Parameter 15-43 Software Version.*
- *Parameter 15-45 Actual Typecode String.*
- *Parameter 15-49 SW ID Control Card.*
- *Parameter 15-50 SW ID Power Card.*
- *Parameter 15-60 Option Mounted.*
- *Parameter 15-61 Option SW Version (for each option slot).*

ALARM 16, Short circuit

There is short-circuiting in the motor or motor wiring.

Troubleshooting

- Remove the power to the frequency converter and repair the short circuit.

⚠ WARNING**HIGH VOLTAGE**

Frequency converters contain high voltage when connected to AC mains input, DC supply, or load sharing. Failure to use qualified personnel to install, start up, and maintain the frequency converter can result in death or serious injury.

- **Disconnect power before proceeding.**

WARNING/ALARM 17, Control word timeout

There is no communication to the frequency converter. The warning is only active when *parameter 8-04 Control Timeout Function* is NOT set to [0] Off.

If *parameter 8-04 Control Timeout Function* is set to [5] Stop and trip, a warning appears, and the frequency converter ramps down to a stop and shows an alarm.

Troubleshooting

- Check the connections on the serial communication cable.
- Increase *parameter 8-03 Control Timeout Time*.
- Check the operation of the communication equipment.
- Verify that proper EMC installation was performed.

WARNING/ALARM 20, Temp. input error

The temperature sensor is not connected.

WARNING/ALARM 21, Parameter error

The parameter is out of range. The parameter number is reported in the display.

Troubleshooting

- Set the affected parameter to a valid value.

WARNING/ALARM 22, Hoist mechanical brake

The value of this warning/alarm shows the type of warning/alarm.

0 = The torque reference was not reached before timeout (*parameter 2-27 Torque Ramp Up Time*).

1 = Expected brake feedback was not received before timeout (*parameter 2-23 Activate Brake Delay*, *parameter 2-25 Brake Release Time*).

WARNING 23, Internal fan fault

The fan warning function is a protective function that checks if the fan is running/mounted. The fan warning can be disabled in *parameter 14-53 Fan Monitor ([0] Disabled)*.

For frequency converters with DC fans, a feedback sensor is mounted in the fan. If the fan is commanded to run and there is no feedback from the sensor, this alarm appears. For frequency converters with AC fans, the voltage to the fan is monitored.

Troubleshooting

- Check for proper fan operation.
- Cycle power to the frequency converter and check that the fan operates briefly at start-up.
- Check the sensors on the control card.

WARNING 24, External fan fault

The fan warning function is a protective function that checks if the fan is running/mounted. The fan warning can be disabled in *parameter 14-53 Fan Monitor ([0] Disabled)*.

For frequency converters with DC fans, a feedback sensor is mounted in the fan. If the fan is commanded to run and there is no feedback from the sensor, this alarm appears. For frequency converters with AC fans, the voltage to the fan is monitored.

Troubleshooting

- Check for proper fan operation.
- Cycle power to the frequency converter and check that the fan operates briefly at start-up.
- Check the sensors on the heat sink.

WARNING 25, Brake resistor short circuit

The brake resistor is monitored during operation. If a short circuit occurs, the brake function is disabled and the warning appears. The frequency converter is still operational, but without the brake function.

Troubleshooting

- Remove the power to the frequency converter and replace the brake resistor (refer to *parameter 2-15 Brake Check*).

WARNING/ALARM 26, Brake resistor power limit

The power transmitted to the brake resistor is calculated as a mean value over the last 120 s of run time. The calculation is based on the DC-link voltage and the brake resistor value set in *parameter 2-16 AC brake Max. Current*. The warning is active when the dissipated braking power is higher than 90% of the brake resistor power. If option [2] *Trip* is selected in *parameter 2-13 Brake Power Monitoring*, the frequency converter trips when the dissipated braking power reaches 100%.

WARNING/ALARM 27, Brake chopper fault

The brake transistor is monitored during operation, and if a short circuit occurs, the brake function is disabled, and a warning is issued. The frequency converter is still operational, but since the brake transistor has short-circuited, substantial power is transmitted to the brake resistor, even if it is inactive.

Troubleshooting

- Remove power to the frequency converter and remove the brake resistor.

WARNING/ALARM 28, Brake check failed

The brake resistor is not connected or not working.

Troubleshooting

- Check *parameter 2-15 Brake Check*.

ALARM 30, Motor phase U missing

Motor phase U between the frequency converter and the motor is missing.

WARNING**HIGH VOLTAGE**

Frequency converters contain high voltage when connected to AC mains input, DC supply, or load sharing. Failure to use qualified personnel to install, start up, and maintain the frequency converter can result in death or serious injury.

- **Disconnect power before proceeding.**

Troubleshooting

- Remove the power from the frequency converter and check motor phase U.

ALARM 31, Motor phase V missing

Motor phase V between the frequency converter and the motor is missing.

WARNING**HIGH VOLTAGE**

Frequency converters contain high voltage when connected to AC mains input, DC supply, or load sharing. Failure to use qualified personnel to install, start up, and maintain the frequency converter can result in death or serious injury.

- **Disconnect power before proceeding.**

Troubleshooting

- Remove the power from the frequency converter and check motor phase V.

ALARM 32, Motor phase W missing

Motor phase W between the frequency converter and the motor is missing.

WARNING**HIGH VOLTAGE**

Frequency converters contain high voltage when connected to AC mains input, DC supply, or load sharing. Failure to use qualified personnel to install, start up, and maintain the frequency converter can result in death or serious injury.

- **Disconnect power before proceeding.**

Troubleshooting

- Remove the power from the frequency converter and check motor phase W.

ALARM 33, Inrush fault

Too many power-ups have occurred within a short time period.

Troubleshooting

- Let the unit cool to operating temperature.

WARNING/ALARM 34, Fieldbus communication fault

The fieldbus on the communication option card is not working.

WARNING/ALARM 35, Option fault

An option alarm is received. The alarm is option-specific. The most likely cause is a power-up or a communication fault.

WARNING/ALARM 36, Mains failure

This warning/alarm is only active if the supply voltage to the frequency converter is lost and *parameter 14-10 Mains Failure* is not set to [0] *No function*.

Troubleshooting

- Check the fuses to the frequency converter and mains supply to the unit.

ALARM 37, Phase imbalance

There is a current imbalance between the power units.

ALARM 38, Internal fault

When an internal fault occurs, a code number defined in *Table 7.4* is shown.

Troubleshooting

- Cycle power.
- Check that the option is properly installed.
- Check for loose or missing wiring.

It may be necessary to contact the Danfoss supplier or service department. Note the code number for further troubleshooting directions.

Number	Text
0	The serial port cannot be initialized. Contact the Danfoss supplier or Danfoss service department.
256–258	The power EEPROM data is defective or too old. Replace the power card.
512–519	Internal fault. Contact the Danfoss supplier or Danfoss service department.
783	Parameter value outside of minimum/maximum limits.
1024–1284	Internal fault. Contact the Danfoss supplier or Danfoss service department.
1299	The option software in slot A is too old.
1300	The option software in slot B is too old.
1302	The option software in slot C1 is too old.
1315	The option software in slot A is not supported/allowed.
1316	The option software in slot B is not supported/allowed.
1318	The option software in slot C1 is not supported/allowed.
1379–2819	Internal fault. Contact the Danfoss supplier or Danfoss service department.
1792	Hardware reset of digital signal processor.
1793	Motor-derived parameters not transferred correctly to the digital signal processor.
1794	Power data not transferred correctly at power-up to the digital signal processor.
1795	The digital signal processor has received too many unknown SPI telegrams. The frequency converter also uses this fault code if the MCO does not power up correctly. This situation can occur due to poor EMC protection or improper grounding.
1796	RAM copy error.
2561	Replace the control card.
2820	LCP stack overflow.
2821	Serial port overflow.
2822	USB port overflow.
3072–5122	Parameter value is outside its limits.
5123	Option in slot A: Hardware incompatible with the control board hardware.
5124	Option in slot B: Hardware incompatible with the control board hardware.
5125	Option in slot C0: Hardware incompatible with the control board hardware.
5126	Option in slot C1: Hardware incompatible with the control board hardware.
5376–6231	Internal fault. Contact the Danfoss supplier or Danfoss service department.

Table 7.4 Internal Fault Codes

ALARM 39, Heat sink sensor

No feedback from the heat sink temperature sensor.

The signal from the IGBT thermal sensor is not available on the power card. The problem could be on the power card, on the gatedrive card, or the ribbon cable between the power card and gatedrive card.

WARNING 40, Overload of digital output terminal 27

Check the load connected to terminal 27 or remove the short circuit connection. Check *parameter 5-00 Digital I/O Mode* and *parameter 5-01 Terminal 27 Mode*.

WARNING 41, Overload of digital output terminal 29

Check the load connected to terminal 29 or remove the short-circuit connection. Also check *parameter 5-00 Digital I/O Mode* and *parameter 5-02 Terminal 29 Mode*.

WARNING 42, Overload of digital output on X30/6 or overload of digital output on X30/7

For terminal X30/6, check the load connected to terminal X30/6 or remove the short-circuit connection. Also check *parameter 5-32 Term X30/6 Digi Out (MCB 101)* (VLT® General Purpose I/O MCB 101).

For terminal X30/7, check the load connected to terminal X30/7 or remove the short-circuit connection. Check *parameter 5-33 Term X30/7 Digi Out (MCB 101)* (VLT® General Purpose I/O MCB 101).

ALARM 43, Ext. supply

VLT® Extended Relay Option MCB 113 is mounted without external 24 V DC. Either connect a 24 V DC external supply or specify that no external supply is used via *parameter 14-80 Option Supplied by External 24VDC, [0] No*. A change in *parameter 14-80 Option Supplied by External 24VDC* requires a power cycle.

ALARM 45, Earth fault 2

Ground fault.

Troubleshooting

- Check for proper grounding and loose connections.
- Check for proper wire size.
- Check the motor cables for short circuits or leakage currents.

ALARM 46, Power card supply

The supply on the power card is out of range.

There are 3 supplies generated by the switch mode supply (SMPS) on the power card:

- 24 V.
- 5 V.
- ±18 V.

When powered with VLT® 24 V DC Supply MCB 107, only the 24 V and 5 V supplies are monitored. When powered with 3-phase mains voltage, all 3 supplies are monitored.

Troubleshooting

- Check for a defective power card.
- Check for a defective control card.
- Check for a defective option card.
- If a 24 V DC supply is used, verify proper supply power.

WARNING 47, 24 V supply low

The supply on the power card is out of range.

There are 3 supplies generated by the switch mode supply (SMPS) on the power card:

- 24 V.
- 5 V.
- ± 18 V.

Troubleshooting

- Check for a defective power card.

WARNING 48, 1.8 V supply low

The 1.8 V DC supply used on the control card is outside of the allowable limits. The supply is measured on the control card.

Troubleshooting

- Check for a defective control card.
- If an option card is present, check for overvoltage.

WARNING 49, Speed limit

The warning is shown when the speed is outside of the specified range in *parameter 4-11 Motor Speed Low Limit [RPM]* and *parameter 4-13 Motor Speed High Limit [RPM]*. When the speed is below the specified limit in *parameter 1-86 Compressor Min. Speed for Trip [RPM]* (except when starting or stopping), the frequency converter trips.

ALARM 50, AMA calibration failed

Contact the Danfoss supplier or Danfoss service department.

ALARM 51, AMA check U_{nom} and I_{nom}

The settings for motor voltage, motor current, and motor power are wrong.

Troubleshooting

- Check the settings in *parameters 1-20 to 1-25*.

ALARM 52, AMA low I_{nom}

The motor current is too low.

Troubleshooting

- Check the settings in *parameter 1-24 Motor Current*.

ALARM 53, AMA motor too big

The motor is too large for the AMA to operate.

ALARM 54, AMA motor too small

The motor is too small for the AMA to operate.

ALARM 55, AMA parameter out of range

The AMA cannot run because the parameter values of the motor are outside of the acceptable range.

ALARM 56, AMA interrupted by user

The AMA is manually interrupted.

ALARM 57, AMA internal fault

Try to restart the AMA. Repeated restarts can overheat the motor.

ALARM 58, AMA Internal fault

Contact the Danfoss supplier.

WARNING 59, Current limit

The current is higher than the value in *parameter 4-18 Current Limit*. Ensure that the motor data in *parameters 1-20 to 1-25* is set correctly. Increase the current limit if necessary. Ensure that the system can operate safely at a higher limit.

WARNING 60, External interlock

A digital input signal indicates a fault condition external to the frequency converter. An external interlock has commanded the frequency converter to trip. Clear the external fault condition. To resume normal operation, apply 24 V DC to the terminal programmed for external interlock, and reset the frequency converter.

WARNING/ALARM 61, Feedback error

An error between calculated speed and speed measurement from feedback device.

Troubleshooting

- Check the settings for warning/alarm/disabling in *parameter 4-30 Motor Feedback Loss Function*.
- Set the tolerable error in *parameter 4-31 Motor Feedback Speed Error*.
- Set the tolerable feedback loss time in *parameter 4-32 Motor Feedback Loss Timeout*.

WARNING 62, Output frequency at maximum limit

The output frequency has reached the value set in *parameter 4-19 Max Output Frequency*. Check the application for possible causes. Possibly increase the output frequency limit. Be sure that the system can operate safely at a higher output frequency. The warning clears when the output drops below the maximum limit.

ALARM 63, Mechanical brake low

The actual motor current has not exceeded the release brake current within the start delay time window.

WARNING 64, Voltage Limit

The load and speed combination demands a motor voltage higher than the actual DC-link voltage.

WARNING/ALARM 65, Control card over temperature

The cutout temperature of the control card is 85 °C (185 °F).

Troubleshooting

- Check that the ambient operating temperature is within the limits.
- Check for clogged filters.
- Check the fan operation.
- Check the control card.

WARNING 66, Heat sink temperature low

The frequency converter is too cold to operate. This warning is based on the temperature sensor in the IGBT module. Increase the ambient temperature of the unit. Also, a trickle amount of current can be supplied to the frequency converter whenever the motor is stopped by setting *parameter 2-00 DC Hold/Preheat Current* to 5% and *parameter 1-80 Function at Stop*.

ALARM 67, Option module configuration has changed

One or more options have either been added or removed since the last power-down. Check that the configuration change is intentional and reset the unit.

ALARM 68, Safe Stop activated

Safe torque off (STO) has been activated. To resume normal operation, apply 24 V DC to terminal 37, then send a reset signal (via bus, digital I/O, or by pressing [Reset]).

ALARM 69, Power card temperature

The temperature sensor on the power card is either too hot or too cold.

Troubleshooting

- Check that the ambient operating temperature is within limits.
- Check for clogged filters.
- Check fan operation.
- Check the power card.

ALARM 70, Illegal FC configuration

The control card and power card are incompatible. To check compatibility, contact the Danfoss supplier with the type code from the unit nameplate and the part numbers of the cards.

ALARM 71, PTC 1 safe stop

STO has been activated from the VLT® PTC Thermistor Card MCB 112 (motor too warm). Normal operation can be resumed when the MCB 112 applies 24 V DC to terminal 37 again (when the motor temperature reaches an acceptable level), and when the digital input from the MCB 112 is deactivated. When that happens, send a reset signal (via bus or digital I/O, or press [Reset]).

ALARM 72, Dangerous failure

STO with trip lock. An unexpected combination of STO commands has occurred:

- VLT® PTC Thermistor Card MCB 112 enables X44/10, but STO is not enabled.
- MCB 112 is the only device using STO (specified through selection [4] *PTC 1 alarm* or [5] *PTC 1 warning* in *parameter 5-19 Terminal 37 Safe Stop*), STO is activated, and X44/10 is not activated.

WARNING 73, Safe Stop auto restart

STO activated. With automatic restart enabled, the motor can start when the fault is cleared.

ALARM 74, PTC Thermistor

Alarm related to VLT® PTC Thermistor Card MCB 112. The PTC is not working.

ALARM 75, Illegal profile sel.

Do not write the parameter value while the motor is running. Stop the motor before writing the MCO profile to *parameter 8-10 Control Profile*.

WARNING 77, Reduced power mode

The frequency converter is operating in reduced power mode (less than the allowed number of inverter sections). This warning is generated on power cycle when the frequency converter is set to run with fewer inverters and remains on.

ALARM 78, Tracking error

The difference between setpoint value and actual value exceeds the value in *parameter 4-35 Tracking Error*.

Troubleshooting

- Disable the function or select an alarm/warning in *parameter 4-34 Tracking Error Function*.
- Investigate the mechanics around the load and motor. Check feedback connections from motor encoder to frequency converter.
- Select motor feedback function in *parameter 4-30 Motor Feedback Loss Function*.
- Adjust the tracking error band in *parameter 4-35 Tracking Error* and *parameter 4-37 Tracking Error Ramping*.

ALARM 79, Illegal power section configuration

The scaling card has an incorrect part number or is not installed. The MK102 connector on the power card could not be installed.

ALARM 80, Drive initialised to default value

Parameter settings are initialized to default settings after a manual reset. To clear the alarm, reset the unit.

ALARM 81, CSIV corrupt

CSIV file has syntax errors.

ALARM 82, CSIV parameter error

CSIV failed to initialize a parameter.

ALARM 83, Illegal option combination

The mounted options are incompatible.

ALARM 84, No safety option

The safety option was removed without applying a general reset. Reconnect the safety option.

ALARM 88, Option detection

A change in the option layout is detected. *Parameter 14-89 Option Detection* is set to [0] *Frozen configuration* and the option layout has been changed.

- To apply the change, enable option layout changes in *parameter 14-89 Option Detection*.
- Alternatively, restore the correct option configuration.

WARNING 89, Mechanical brake sliding

The hoist brake monitor detects a motor speed exceeding 10 RPM.

ALARM 90, Feedback monitor

Check the connection to encoder/resolver option and, if necessary, replace VLT® Encoder Input MCB 102 or VLT® Resolver Input MCB 103.

ALARM 91, Analog input 54 wrong settings

Set switch S202 in position OFF (voltage input) when a KTY sensor is connected to analog input terminal 54.

ALARM 99, Locked rotor

Rotor is blocked.

WARNING/ALARM 104, Mixing fan fault

The fan is not operating. The fan monitor checks that the fan is spinning at power-up or whenever the mixing fan is turned on. The mixing-fan fault can be configured as a warning or an alarm trip in *parameter 14-53 Fan Monitor*.

Troubleshooting

- Cycle power to the frequency converter to determine if the warning/alarm returns.

WARNING/ALARM 122, Mot. rotat. unexp.

The frequency converter performs a function that requires the motor to be at standstill, for example DC hold for PM motors.

WARNING 163, ATEX ETR cur.lim.warning

The frequency converter has run above the characteristic curve for more than 50 s. The warning is activated at 83% and deactivated at 65% of the allowed thermal overload.

ALARM 164, ATEX ETR cur.lim.alarm

Operating above the characteristic curve for more than 60 s within a period of 600 s activates the alarm, and the frequency converter trips.

WARNING 165, ATEX ETR freq.lim.warning

The frequency converter is running for more than 50 s below the allowed minimum frequency (*parameter 1-98 ATEX ETR interpol. points freq.*).

ALARM 166, ATEX ETR freq.lim.alarm

The frequency converter has operated for more than 60 s (in a period of 600 s) below the allowed minimum frequency (*parameter 1-98 ATEX ETR interpol. points freq.*).

WARNING 251, New typecode

The power card or other components are replaced, and the type code has changed.

WARNING 250, New spare part

The power or switch mode supply has been exchanged. Restore the frequency converter type code in the EEPROM. Select the correct type code in *parameter 14-23 Typecode Setting* according to the label on the frequency converter. Remember to select Save to EEPROM at the end.

7.7 Troubleshooting

Symptom	Possible cause	Test	Solution
Display dark/No function	Missing input power.	See <i>Table 4.5</i> .	Check the input power source.
	Missing or open fuses, or circuit breaker tripped.	See <i>Open power fuses and tripped circuit breaker</i> in this table for possible causes.	Follow the recommendations provided.
	No power to the LCP.	Check the LCP cable for proper connection or damage.	Replace the faulty LCP or connection cable.
	Short circuit on control voltage (terminal 12 or 50) or at control terminals.	Check the 24 V control voltage supply for terminal 12/13 to 20–39, or 10 V supply for terminal 50–55.	Wire the terminals properly.
	Incompatible LCP (LCP from VLT® 2800 or 5000/6000/8000/ FCD or FCM).	–	Use only LCP 101 (P/N 130B1124) or LCP 102 (P/N. 130B1107).
	Wrong contrast setting.	–	Press [Status] + [▲]/[▼] to adjust the contrast.
	Display (LCP) is defective.	Test using a different LCP.	Replace the faulty LCP or connection cable.
	Internal voltage supply fault or SMPS is defective.	–	Contact supplier.
Intermittent display	Overloaded supply (SMPS) due to improper control wiring or a fault within the frequency converter.	To rule out a problem in the control wiring, disconnect all control wiring by removing the terminal blocks.	If the display stays lit, the problem is in the control wiring. Check the wiring for shorts or incorrect connections. If the display continues to cut out, follow the procedure for <i>Display dark/No function</i> .
Motor not running	Service switch open or missing motor connection.	Check if the motor is connected and the connection is not interrupted by a service switch or other device.	Connect the motor and check the service switch.
	No mains power with 24 V DC option card.	If the display is functioning, but there is no output, check that mains power is applied to the frequency converter.	Apply mains power to run the unit.
	LCP stop.	Check if [Off] has been pressed.	Press [Auto On] or [Hand On] (depending on operating mode) to run the motor.
	Missing start signal (Standby).	Check <i>parameter 5-10 Terminal 18 Digital Input</i> for correct setting of terminal 18. Use default setting.	Apply a valid start signal to start the motor.
	Motor coast signal active (Coasting).	Check <i>parameter 5-12 Terminal 27 Digital Input</i> for correct setting of terminal 27 (use default setting).	Apply 24 V on terminal 27 or program this terminal to [0] <i>No operation</i> .
	Wrong reference signal source.	Check reference signal: <ul style="list-style-type: none"> • Local. • Remote or bus reference? • Preset reference active? • Terminal connection correct? • Scaling of terminals correct? • Reference signal available? 	Program correct settings. Check <i>parameter 3-13 Reference Site</i> . Set preset reference active in <i>parameter group 3-1* References</i> . Check for correct wiring. Check scaling of terminals. Check reference signal.
Motor running in wrong direction	Motor rotation limit.	Check that <i>parameter 4-10 Motor Speed Direction</i> is programmed correctly.	Program correct settings.
	Active reversing signal.	Check if a reversing command is programmed for the terminal in <i>parameter group 5-1* Digital inputs</i> .	Deactivate reversing signal.
	Wrong motor phase connection.	–	See <i>chapter 5.5 Checking Motor Rotation</i> .

Symptom	Possible cause	Test	Solution
Motor is not reaching maximum speed	Frequency limits set wrong.	Check output limits in <i>parameter 4-13 Motor Speed High Limit [RPM]</i> , <i>parameter 4-14 Motor Speed High Limit [Hz]</i> , and <i>parameter 4-19 Max Output Frequency</i> .	Program correct limits.
	Reference input signal not scaled correctly.	Check reference input signal scaling in <i>parameter group 6-0* Analog I/O mode</i> and <i>parameter group 3-1* References..</i>	Program correct settings.
Motor speed unstable	Possible incorrect parameter settings.	Check the settings of all motor parameters, including all motor compensation settings. For closed-loop operation, check PID settings.	Check settings in <i>parameter group 1-6* Load Depen. Setting</i> . For closed-loop operation, check settings in <i>parameter group 20-0* Feedback</i> .
Motor runs rough	Possible overmagnetization.	Check for incorrect motor settings in all motor parameters.	Check motor settings in <i>parameter groups 1-2* Motor data</i> , <i>1-3* Adv Motor Data</i> , and <i>1-5* Load Indep. Setting</i> .
Motor does not brake	Possible incorrect settings in the brake parameters. Ramp-down times may be too short.	Check brake parameters. Check ramp time settings.	Check <i>parameter groups 2-0* DC Brake</i> and <i>3-0* Reference Limits</i> .
Open power fuses	Phase-to-phase short.	Motor or panel has a short phase-to-phase. Check motor and panel phases for shorts.	Eliminate any shorts detected.
	Motor overload.	Motor is overloaded for the application.	Perform start-up test and verify that the motor current is within specifications. If the motor current exceeds the nameplate full-load current, the motor may run only with reduced load. Review the specifications for the application.
	Loose connections.	Perform pre-start-up check for loose connections.	Tighten loose connections.
Mains current imbalance greater than 3%	Problem with mains power (see <i>Alarm 4, Mains phase loss</i> description).	Rotate input power leads into the 1 position: A to B, B to C, C to A.	If imbalanced leg follows the wire, it is a power problem. Check the mains supply.
	Problem with the frequency converter.	Rotate input power leads into the frequency converter 1 position: A to B, B to C, C to A.	If the imbalanced leg stays on same input terminal, it is a problem with the frequency converter. Contact the supplier.
Motor current imbalance greater than 3%	Problem with motor or motor wiring.	Rotate output motor leads 1 position: U to V, V to W, W to U.	If the imbalanced leg follows the wire, the problem is in the motor or motor wiring. Check motor and motor wiring.
	Problem with frequency converter.	Rotate output motor leads 1 position: U to V, V to W, W to U.	If the imbalanced leg stays on same output terminal, it is a problem with the unit. Contact the supplier.
Frequency converter acceleration problems	Motor data is entered incorrectly.	If warnings or alarms occur, see <i>chapter 7.6 List of Warnings and Alarms</i> . Check that motor data is entered correctly.	Increase the ramp-up time in <i>parameter 3-41 Ramp 1 Ramp Up Time</i> . Increase current limit in <i>parameter 4-18 Current Limit</i> . Increase torque limit in <i>parameter 4-16 Torque Limit Motor Mode</i> .
Frequency converter deceleration problems	Motor data is entered incorrectly.	If warnings or alarms occur, see <i>chapter 7.6 List of Warnings and Alarms</i> . Check that motor data is entered correctly.	Increase the ramp-down time in <i>parameter 3-42 Ramp 1 Ramp Down Time</i> . Enable overvoltage control in <i>parameter 2-17 Over-voltage Control</i> .

Table 7.5 Troubleshooting

8 Specifications

8.1 Electrical Data

8.1.1 Mains Supply 3x380–500 V AC

	N110	N132	N160	N200	N250	N315
Normal load*	NO	NO	NO	NO	NO	NO
Typical shaft output at 400 V [kW]	110	132	160	200	250	315
Typical shaft output at 460 V [hp]	150	200	250	300	350	450
Enclosure IP21	D1h	D1h	D1h	D2h	D2h	D2h
Enclosure IP54	D1h	D1h	D1h	D2h	D2h	D2h
Enclosure IP20	D3h	D3h	D3h	D4h	D4h	D4h
Output current						
Continuous (at 400 V) [A]	212	260	315	395	480	588
Intermittent (60 s overload) (at 400 V)[A]	233	286	347	435	528	647
Continuous (at 460/480 V) [A]	190	240	302	361	443	535
Intermittent (60 s overload) (at 460/480 V) [kVA]	209	264	332	397	487	588
Continuous kVA (at 400 V) [kVA]	147	180	218	274	333	407
Continuous kVA (at 460 V) [kVA]	151	191	241	288	353	426
Maximum input current						
Continuous (at 400 V) [A]	204	251	304	381	463	567
Continuous (at 460/480 V) [A]	183	231	291	348	427	516
Maximum external mains fuses [A]	315	350	400	550	630	800
Maximum cable size						
Maximum cable size: Mains, motor, and load sharing mm ² (AWG)]	2 x95 (2x3/0)			2x185 (2x350)		
Maximum cable size: Brake mm ² (AWG)]	2 x95 (2x3/0)			2x185 (2x350)		
Estimated power loss at 400 V [W]	2555	2949	3764	4109	5129	6663
Estimated power loss at 460 V [W]	2257	2719	3612	3561	4558	5703
Weight, enclosure IP21, IP54 [kg (lbs)]	62 (135)			125 (275)		
Weight, enclosure IP20 [kg (lbs)]	62 (135)			125 (275)		
Efficiency	0.98					
Output frequency [Hz]	0–590 Hz					
Heat sink overtemperature trip [°C (°F)]	110 (230)					
Power card ambient trip [°C (°F)]	75 (167)					
*Normal overload=110% current for 60 s						

Table 8.1 Mains Supply 3x380–480 V AC

	N75K	N90K	N110	N132	N160	N200
Normal load*	NO	NO	NO	NO	NO	NO
Typical shaft output at 550 V [kW]	55	75	90	110	132	160
Typical shaft output at 575 V [hp]	75	100	125	150	200	250
Typical shaft output at 690 V [kW]	75	90	110	132	160	200
Enclosure IP21	D1h	D1h	D1h	D1h	D1h	D2h
Enclosure IP54	D1h	D1h	D1h	D1h	D1h	D2h
Enclosure IP20	D3h	D3h	D3h	D3h	D3h	D4h
Output current						
Continuous (at 550 V) [A]	90	113	137	162	201	253
Intermittent (60 s overload) (at 550 V)[A]	99	124	151	178	221	278
Continuous (at 575/690 V) [A]	86	108	131	155	192	242
Intermittent (60 s overload) (at 575/690 V) [kVA]	95	119	144	171	211	266
Continuous kVA (at 550 V) [kVA]	86	108	131	154	191	241
Continuous kVA (at 575 V) [kVA]	86	108	130	154	191	241
Continuous kVA (at 690 V) [kVA]	103	129	157	185	229	289
Maximum input current						
Continuous (at 550 V) [A]	89	110	130	158	198	245
Continuous (at 575 V) [A]	85	106	124	151	189	234
Continuous (at 690 V) [A]	87	109	128	155	197	240
Maximum cable size: Mains, motor, and load sharing [mm ² (AWG)]	2x95 (2x3/0)					
Maximum cable size: Brake [mm ² (AWG)]	2x95 (2x3/0)					
Maximum external mains fuses [A]	160	315	315	315	350	350
Estimated power loss at 575 V [W]	1161	1426	1739	2099	2646	3071
Estimated power loss at 690 V [W]	1203	1476	1796	2165	2738	3172
Weight, enclosure IP21, IP54 [kg (lbs)]	62 (135)					125 (275)
Weight, enclosure IP20 [kg (lbs)]	62 (135)					125 (275)
Efficiency	0.98					
Output frequency	0–590 Hz					
Heat sink overtemperature trip [°C (°F)]	110 (230)					
Power card ambient trip [°C (°F)]	75 (167)					
*Normal overload=110% current for 60 s						

Table 8.2 Mains Supply 3x525–690 V AC

- The typical power loss is at nominal load conditions and expected to be within $\pm 15\%$ (tolerance relates to variety in voltage and cable conditions).
- The losses are based on the default switching frequency. The losses increase significantly at higher switching frequencies.

8.1.2 Mains Supply 3x525–690 V AC

	N250	N315	N400
Normal load*	NO	NO	NO
Typical shaft output at 550 V [kW]	200	250	315
Typical shaft output at 575 V [hp]	300	350	400
Typical shaft output at 690 V [kW]	250	315	400
Enclosure IP21	D2h	D2h	D2h
Enclosure IP54	D2h	D2h	D2h
Enclosure IP20	D4h	D4h	D4h
Output current			
Continuous (at 550 V) [A]	303	360	418
Intermittent (60 s overload) (at 550 V) [A]	333	396	460
Continuous (at 575/690 V) [A]	290	344	400
Intermittent (60 s overload) (at 575/690 V) [kVA]	319	378	440
Continuous kVA (at 550 V) [kVA]	289	343	398
Continuous kVA (at 575 V) [kVA]	289	343	398
Continuous kVA (at 690 V) [kVA]	347	411	478
Maximum input current			
Continuous (at 550 V) [A]	299	355	408
Continuous (at 575 V) [A]	286	339	390
Continuous (at 690 V) [A]	296	352	400
Maximum cable size: Mains, motor, and load sharing, [mm ² (AWG)]	2x185 (2x350 mcm)		
Maximum cable size: Brake, [mm ² (AWG)]	2x185 (2x350 mcm)		
Maximum external mains fuses [A]	400	500	550
Estimated power loss at 575 V [W]	3719	4460	5023
Estimated power loss at 690 V [W]	3848	4610	5150
Weight, enclosure IP21, IP54 [kg (lbs)]	125 (275)		
Weight, enclosure IP20 [kg (lbs)]	125 (275)		
Efficiency	0.98		
Output frequency [Hz]	0–590		0–525
Heat sink overtemperature trip [°C (°F)]	110 (230)		
Power card ambient trip [°C (°F)]	80 (176)		
*Normal overload=110% current for 60 s			

Table 8.3 Mains Supply 3x525–690 V AC

- The typical power loss is at nominal load conditions and expected to be within ±15% (tolerance relates to variety in voltage and cable conditions).
- The losses are based on the default switching frequency. The losses increase significantly at higher switching frequencies.

8.2 Mains Supply

Mains supply (L1, L2, L3)

Supply voltage	380–480 V ±10%, 525–690 V ±10%
----------------	--------------------------------

Mains voltage low/mains voltage dropout:

During low mains voltage or a mains drop-out, the frequency converter continues until the DC-link voltage drops below the minimum stop level. The minimum stop level corresponds typically to 15% below the frequency converter's lowest rated supply voltage. Power-up and full torque cannot be expected at mains voltage lower than 10% below the frequency converter's lowest rated supply voltage.

Supply frequency	50/60 Hz ±5%
------------------	--------------

Maximum imbalance temporary between mains phases	3.0% of rated supply voltage
--	------------------------------

True power factor (λ)	±0.9 nominal at rated load
---------------------------------	----------------------------

Displacement power factor ($\cos \varphi$) near unity	(>0.98)
---	---------

Switching on input supply L1, L2, L3 (power-ups)	Maximum 1 time/2 minutes
--	--------------------------

Environment according to EN60664-1	Overvoltage category III/pollution degree 2
------------------------------------	---

The unit is suitable for use on a circuit capable of delivering not more than 100000 RMS symmetrical Amperes, 480/600 V.

8.3 Motor Output and Motor Data

Motor output (U, V, W)

Output voltage	0–100% of supply voltage
----------------	--------------------------

Output frequency	0–590 Hz ¹⁾
------------------	------------------------

Switching on output	Unlimited
---------------------	-----------

Ramp times	0.01–3600 s
------------	-------------

1) Dependent on voltage and power.

Torque characteristics

Starting torque (constant torque)	Maximum 160% for 60 s ¹⁾
-----------------------------------	-------------------------------------

Starting torque	Maximum 180% up to 0.5 s ¹⁾
-----------------	--

Overload torque (constant torque)	Maximum 160% for 60 s ¹⁾
-----------------------------------	-------------------------------------

1) Percentage relates to the frequency converter's nominal torque.

8.4 Ambient Conditions

Environment

Enclosure size D1h/D2h/D5h/D6h/D7h/D8h	IP21/Type 1, IP54/Type12
--	--------------------------

Enclosure size D3h/D4h	IP20/Chassis
------------------------	--------------

Vibration test all enclosure sizes	1.0 g
------------------------------------	-------

Relative humidity	5–95% (IEC 721-3-3; Class 3K3 (non-condensing) during operation)
-------------------	--

Aggressive environment (IEC 60068-2-43) H ₂ S test	Class Kd
---	----------

Test method according to IEC 60068-2-43 H ₂ S (10 days)	
--	--

Ambient temperature (at SFAVM switching mode)	
---	--

- with derating	Maximum 55 °C (maximum 131 °F) ¹⁾
-----------------	--

- with full output power of typical EFF2 motors (up to 90% output current)	Maximum 50 °C (maximum 122 °F) ¹⁾
--	--

- at full continuous FC output current	Maximum 45 °C (maximum 113 °F) ¹⁾
--	--

Minimum ambient temperature during full-scale operation	0 °C (32 °F)
---	--------------

Minimum ambient temperature at reduced performance	10 °C (50 °F)
--	---------------

Temperature during storage/transport	-25 to +65/70 °C (13 to 149/158 °F)
--------------------------------------	-------------------------------------

Maximum altitude above sea level without derating	1000 m (3281 ft)
---	------------------

Maximum altitude above sea level with derating	3000 m (9842 ft)
--	------------------

1) For more information on derating, see section on special conditions in the design guide.

EMC standards, Emission	EN 61800-3
-------------------------	------------

EMC standards, Immunity	EN 61800-3
-------------------------	------------

Energy efficiency class²⁾ IE2

2) Determined according to EN 50598-2 at:

- Rated load.
- 90% rated frequency.
- Switching frequency factory setting.
- Switching pattern factory setting.

8.5 Cable Specifications

Cable lengths and cross-sections for control cables¹⁾

Maximum motor cable length, shielded/armored	150 m (492 ft)
Maximum motor cable length, unshielded/unarmored	300 m (984 ft)
Maximum cross-section to motor, mains, load sharing, and brake	See chapter 8.1 Electrical Data
Maximum cross-section to control terminals, rigid wire	1.5 mm ² /16 AWG (2x0.75 mm ²)
Maximum cross-section to control terminals, flexible cable	1 mm ² /18 AWG
Maximum cross-section to control terminals, cable with enclosed core	0.5 mm ² /20 AWG
Minimum cross-section to control terminals	0.25 mm ² /23 AWG

1) For power cables, see electrical tables in chapter 8.1 Electrical Data.

8

8.6 Control Input/Output and Control Data

Digital inputs

Programmable digital inputs	4 (6)
Terminal number	18, 19, 27 ¹⁾ , 29 ¹⁾ , 32, 33
Logic	PNP or NPN
Voltage level	0–24 V DC
Voltage level, logic 0 PNP	<5 V DC
Voltage level, logic 1 PNP	>10 V DC
Voltage level, logic 0 NPN	>19 V DC
Voltage level, logic 1 NPN	<14 V DC
Maximum voltage on input	28 V DC
Input resistance, R _i	Approximately 4 kΩ

All digital inputs are galvanically isolated from the supply voltage (PELV) and other high-voltage terminals.

1) Terminals 27 and 29 can also be programmed as outputs.

Analog inputs

Number of analog inputs	2
Terminal number	53, 54
Modes	Voltage or current
Mode select	Switches A53 and A54
Voltage mode	Switch A53/A54=(U)
Voltage level	-10 V to +10 V (scaleable)
Input resistance, R _i	Approximately 10 kΩ
Maximum voltage	±20 V
Current mode	Switch A53/A54=(I)
Current level	0/4 to 20 mA (scaleable)
Input resistance, R _i	Approximately 200 Ω
Maximum current	30 mA
Resolution for analog inputs	10 bit (+ sign)
Accuracy of analog inputs	Maximum error 0.5% of full scale
Bandwidth	100 Hz

The analog inputs are galvanically isolated from the supply voltage (PELV) and other high-voltage terminals.

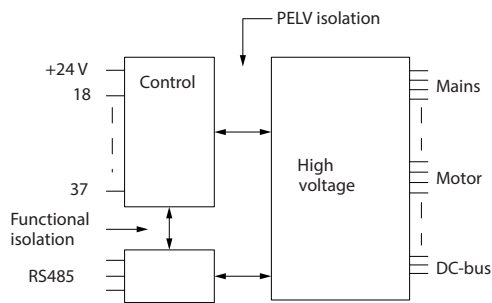

1306A117:10

Illustration 8.1 PELV Isolation

Pulse inputs

Programmable pulse inputs	2
Terminal number pulse	29, 33
Maximum frequency at terminal 29, 33	110 kHz (push-pull driven)
Maximum frequency at terminal 29, 33	5 kHz (open collector)
Minimum frequency at terminal 29, 33	4 Hz
Voltage level	See <i>Digital Inputs</i> in chapter 8.6 <i>Control Input/Output and Control Data</i>
Maximum voltage on input	28 V DC
Input resistance, R_i	Approximately 4 k Ω
Pulse input accuracy (0.1–1 kHz)	Maximum error: 0.1% of full scale

Analog output

Number of programmable analog outputs	1
Terminal number	42
Current range at analog output	0/4-20 mA
Maximum resistor load to common at analog output	500 Ω
Accuracy on analog output	Maximum error: 0.8% of full scale
Resolution on analog output	8 bit

The analog output is galvanically isolated from the supply voltage (PELV) and other high-voltage terminals.

Control card, RS485 serial communication

Terminal number	68 (P, TX+, RX+), 69 (N, TX-, RX-)
Terminal number 61	Common for terminals 68 and 69

The RS485 serial communication circuit is functionally separated from other central circuits and galvanically isolated from the supply voltage (PELV).

Digital output

Programmable digital/pulse outputs	2
Terminal number	27, 29 ¹⁾
Voltage level at digital/frequency output	0–24 V
Maximum output current (sink or source)	40 mA
Maximum load at frequency output	1 k Ω
Maximum capacitive load at frequency output	10 nF
Minimum output frequency at frequency output	0 Hz
Maximum output frequency at frequency output	32 kHz
Accuracy of frequency output	Maximum error: 0.1% of full scale
Resolution of frequency outputs	12 bit

1) Terminals 27 and 29 can also be programmed as inputs.

The digital output is galvanically isolated from the supply voltage (PELV) and other high-voltage terminals.

Control card, 24 V DC output

Terminal number	12, 13
Maximum load	200 mA

The 24 V DC supply is galvanically isolated from the supply voltage (PELV), but has the same potential as the analog and digital inputs and outputs.

Relay outputs

Programmable relay outputs	2
Maximum cross-section to relay terminals	2.5 mm ² (12 AWG)
Minimum cross-section to relay terminals	0.2 mm ² (30 AWG)
Length of stripped wire	8 mm (0.3 in)
Relay 01 terminal number	1–3 (break), 1–2 (make)
Maximum terminal load (AC-1) ¹⁾ on 1–2 (NO) (Resistive load) ²⁾³⁾	400 V AC, 2 A
Maximum terminal load (AC-15) ¹⁾ on 1–2 (NO) (Inductive load @ cosφ 0.4)	240 V AC, 0.2 A
Maximum terminal load (DC-1) ¹⁾ on 1–2 (NO) (Resistive load)	80 V DC, 2 A
Maximum terminal load (DC-13) ¹⁾ on 1–2 (NO) (Inductive load)	24 V DC, 0.1 A
Maximum terminal load (AC-1) ¹⁾ on 1–3 (NC) (Resistive load)	240 V AC, 2 A
Maximum terminal load (AC-15) ¹⁾ on 1–3 (NC) (Inductive load @ cosφ 0.4)	240 V AC, 0.2 A
Maximum terminal load (DC-1) ¹⁾ on 1–3 (NC) (Resistive load)	50 V DC, 2 A
Maximum terminal load (DC-13) ¹⁾ on 1–3 (NC) (Inductive load)	24 V DC, 0.1 A
Minimum terminal load on 1–3 (NC), 1–2 (NO)	24 V DC 10 mA, 24 V AC 2 mA
Environment according to EN 60664-1	Overvoltage category III/pollution degree 2
Relay 02 terminal number	4–6 (break), 4–5 (make)
Maximum terminal load (AC-1) ¹⁾ on 4–5 (NO) (Resistive load) ²⁾³⁾	400 V AC, 2 A
Maximum terminal load (AC-15) ¹⁾ on 4–5 (NO) (Inductive load @ cosφ 0.4)	240 V AC, 0.2 A
Maximum terminal load (DC-1) ¹⁾ on 4–5 (NO) (Resistive load)	80 V DC, 2 A
Maximum terminal load (DC-13) ¹⁾ on 4–5 (NO) (Inductive load)	24 V DC, 0.1 A
Maximum terminal load (AC-1) ¹⁾ on 4–6 (NC) (Resistive load)	240 V AC, 2 A
Maximum terminal load (AC-15) ¹⁾ on 4–6 (NC) (Inductive load @ cosφ 0.4)	240 V AC, 0.2 A
Maximum terminal load (DC-1) ¹⁾ on 4–6 (NC) (Resistive load)	50 V DC, 2 A
Maximum terminal load (DC-13) ¹⁾ on 4–6 (NC) (Inductive load)	24 V DC, 0.1 A
Minimum terminal load on 4–6 (NC), 4–5 (NO)	24 V DC 10 mA, 24 V AC 2 mA
Environment according to EN 60664-1	Overvoltage category III/pollution degree 2

1) IEC 60947 part 4 and 5.

The relay contacts are galvanically isolated from the rest of the circuit by reinforced isolation (PELV).

2) Overvoltage Category II.

3) UL applications 300 V AC 2 A.

Control card, +10 V DC output

Terminal number	50
Output voltage	10.5 V ±0.5 V
Maximum load	25 mA

The 10 V DC supply is galvanically isolated from the supply voltage (PELV) and other high-voltage terminals.

Control characteristics

Resolution of output frequency at 0–1000 Hz	±0.003 Hz
System response time (terminals 18, 19, 27, 29, 32, 33)	≤2 ms
Speed control range (open loop)	1:100 of synchronous speed
Speed accuracy (open loop)	30–4000 RPM: Maximum error of ±8 RPM

All control characteristics are based on a 4-pole asynchronous motor.

Control card performance

Scan interval	5 ms
---------------	------

Control card, USB serial communication

USB standard	1.1 (full speed)
USB plug	USB type B device plug

NOTICE

Connection to PC is carried out via a standard host/device USB cable.
 The USB connection is galvanically isolated from the supply voltage (PELV) and other high-voltage terminals.
 The USB connection is not galvanically isolated from ground. Use only isolated laptop/PC as connection to the USB connector on the frequency converter or an isolated USB cable/converter.

8.7 Fuses

8.7.1 Fuse Selection

Use recommended fuses and/or circuit breakers on the supply side as protection if there is a component breakdown inside the frequency converter (first fault).

NOTICE

Use of fuses on the supply side is mandatory for IEC 60364 (CE) and NEC 2009 (UL) compliant installations.

Use the recommended fuses to ensure compliance with EN 50178. Use of recommended fuses and circuit breakers ensures that possible damage to the frequency converter is limited to damages inside the unit. For further information, see *Application Note Fuses and Circuit Breakers*.

The fuses in *Table 8.4* to *Table 8.6* are suitable for use on a circuit capable of delivering 100000 A_{rms} (symmetrical), depending on the frequency converter voltage rating. With the proper fusing, the frequency converter short-circuit current rating (SCCR) is 100000 A_{rms}.

N110K–N315	380–480 V	Type aR
N75K–N400	525–690 V	Type aR

Table 8.4 Recommended Fuses

Power size	Bussmann PN	Littelfuse PN	Littelfuse PN	Bussmann PN	Siba PN	Ferraz Shawmut PN	Ferraz Shawmut PN (Europe)	Ferraz Shawmut PN (North America)
N110K	170M2619	LA50QS300-4	L50S-300	FWH-300A	20 610 31.315	A50QS300-4	6,9URD31D08A0315	A070URD31KI0315
N132	170M2620	LA50QS350-4	L50S-350	FWH-350A	20 610 31.350	A50QS350-4	6,9URD31D08A0350	A070URD31KI0350
N160	170M2621	LA50QS400-4	L50S-400	FWH-400A	20 610 31.400	A50QS400-4	6,9URD31D08A0400	A070URD31KI0400
N200	170M4015	LA50QS500-4	L50S-500	FWH-500A	20 610 31.550	A50QS500-4	6,9URD31D08A0550	A070URD31KI0550
N250	170M4016	LA50QS600-4	L50S-600	FWH-600A	20 610 31.630	A50QS600-4	6,9URD31D08A0630	A070URD31KI0630
N315	170M4017	LA50QS800-4	L50S-800	FWH-800A	20 610 31.800	A50QS800-4	6,9URD32D08A0800	A070URD31KI0800

Table 8.5 Fuse Options for 380–480 V Frequency Converters

Power size	Bussmann PN	Siba PN	Ferraz Shawmut PN (Europe)	Ferraz Shawmut PN (North America)
N75k T7	170M2616	20 610 31.160	6,9URD30D08A0160	A070URD30KI0160
N90k T7	170M2619	20 610 31.315	6,9URD31D08A0315	A070URD31KI0315
N110 T7	170M2619	20 610 31.315	6,9URD31D08A0315	A070URD31KI0315
N132 T7	170M2619	20 610 31.315	6,9URD31D08A0315	A070URD31KI0315
N160 T7	170M2619	20 610 31.315	6,9URD31D08A0315	A070URD31KI0315
N200 T7	170M4015	20 620 31.550	6,9URD32D08A0550	A070URD32KI0550
N250 T7	170M4015	20 620 31.550	6,9URD32D08A0550	A070URD32KI0550
N315 T7	170M4015	20 620 31.550	6,9URD32D08A0550	A070URD32KI0550
N400 T7	170M4015	20 620 31.550	6,9URD32D08A0550	A070URD32KI0550

Table 8.6 Fuse Options for 525–690 V Frequency Converters

For UL Compliance, use the Bussmann 170M series fuses for units supplied without a contactor-only option. See *Table 8.8* for SCCR ratings and UL fuse criteria if a contactor-only option is supplied with the frequency converter.

8.7.2 Short-circuit Current Rating (SCCR)

If the frequency converter is not supplied with a mains disconnect, contactor or circuit breaker, the short-circuit current rating (SCCR) of the frequency converters is 100000 A at all voltages (380–690 V).

If the frequency converter is supplied with a mains disconnect, the SCCR of the frequency converter is 100000 A at all voltages (380–690 V).

If the frequency converter is supplied with a circuit breaker, the SCCR depends on the voltage, see *Table 8.7*:

	415 V	480 V	600 V	690 V
D6h enclosure	120000 A	100000 A	65000 A	70000 A
D8h enclosure	100000 A	100000 A	42000 A	30000 A

Table 8.7 Frequency Converter Supplied with a Circuit Breaker

If the frequency converter is supplied with a contactor-only option and is externally fused according to *Table 8.8*, the SCCR of the frequency converter is as follows:

	415 V IEC ¹⁾ [A]	480 V UL ²⁾ [A]	600 V UL ²⁾ [A]	690 V IEC ¹⁾ [A]
D6h enclosure	100000	100000	100000	100000
D8h enclosure (not including the N250T5)	100000	100000	100000	100000
D8h enclosure (N250T5 only)	100000	Consult factory	Not applicable	

Table 8.8 Frequency Converter Supplied with a Contactor

1) With a Bussmann type LPJ-SP or Gould Shawmut type AJT fuse. 450 A maximum fuse size for D6h, and 900 A maximum fuse size for D8h.

2) Must use Class J or L branch fuses for UL Approval. 450 A maximum fuse size for D6h, and 600 A maximum fuse size for D8h.

8.8 Connection Tightening Torques

Apply the correct torque when tightening fasteners in the locations that are listed in *Table 8.9*. Too low or too high torque when fastening an electrical connection results in a bad electrical connection. To ensure correct torque, use a torque wrench.

Location	Bolt size	Torque [Nm (in-lb)]
Mains terminals	M10/M12	19 (168)/37 (335)
Motor terminals	M10/M12	19 (168)/37 (335)
Ground terminals	M8/M10	9.6 (84)/19.1 (169)
Brake terminals	M8	9.6 (84)
Load sharing terminals	M10/M12	19 (168)/37 (335)
Regeneration terminals (Enclosures E1h/E2h)	M8	9.6 (84)
Regeneration terminals (Enclosures E3h/E4h)	M10/M12	19 (168)/37 (335)
Relay terminals	–	0.5 (4)
Door/panel cover	M5	2.3 (20)
Gland plate	M5	2.3 (20)
Heat sink access panel	M5	3.9 (35)
Serial communication cover	M5	2.3 (20)

Table 8.9 Fastener Torque Ratings

8

8.9 Power Ratings, Weight, and Dimensions

Enclosure size		D1h	D2h	D3h	D4h	D3h	D4h
		110–160 kW 150–250 hp (380–500 V)	200–315 kW 300–450 hp (380–500 V)	110–160 kW 150–250 hp (380–500 V)	200–315 kW 300–450 hp (380–500 V)	With regeneration or load sharing terminals	
		75–160 kW 75–200 hp (525–690 V)	200–400 kW 300–400 hp (525–690 V)	75–160 kW 75–200 hp (525–690 V)	200–400 kW 300–400 hp (525–690 V)		
IP NEMA		21/54 Type 1/12	21/54 Type 1/12	20 Chassis	20 Chassis	20 Chassis	20 Chassis
Shipping dimensions [mm (in)]	Height	587 (23.1)	587 (23.1)	587 (23.1)	587 (23.1)	587 (23.1)	587 (23.1)
	Width	997 (39.3)	1170 (46.1)	997 (39.3)	1170 (46.1)	1230 (48.4)	1430 (56.3)
	Depth	460 (18.1)	535 (21.1)	460 (18.1)	535 (21.1)	460 (18.1)	535 (21.1)
Frequency converter dimensions [mm (in)]	Height	901 (35.5)	1060 (41.7)	909 (35.8)	1122 (44.2)	1004 (39.5)	1268 (49.9)
	Width	325 (12.8)	420 (16.5)	250 (9.8)	350 (13.8)	250 (9.8)	350 (13.8)
	Depth	378 (14.9)	378 (14.9)	375 (14.7)	375 (14.7)	375 (14.7)	375 (14.8)
Maximum weight [kg (lb)]		98 (216)	164 (362)	98 (216)	164 (362)	108 (238)	179 (395)

Table 8.10 Mechanical Dimensions, Enclosure Sizes D1h-D4h

Enclosure size		D5h	D6h	D7h	D8h
		110–160 kW 150–200 hp (380–500 V)	110–160 kW 150–250 hp (380–500 V)	200–315 kW 300–450 hp (380–500 V)	200–315 kW 300–450 hp (380–500 V)
		75–160 kW 75–200 hp) (525–690 V)	75–160 kW 75–200 hp (525–690 V)	200–400 kW 300–400 hp) (525–690 V)	200–400 kW 300–400 hp (525–690 V)
IP		21/54	21/54	21/54	21/54
NEMA		Type 1/12	Type 1/12	Type 1/12	Type 1/12
Shipping dimensions [mm (in)]	Height	660 (26)	660 (26)	660 (26)	660 (26)
	Width	1820 (71.7)	1820 (71.7)	2470 (97.4)	2470 (97.4)
	Depth	510 (20.1)	510 (20.1)	590 (23.2)	590 (23.2)
Frequency converter dimensions [mm (in)]	Height	1324 (52.1)	1663 (65.5)	1978 (77.9)	2284 (89.9)
	Width	325 (12.8)	325 (12.8)	420 (16.5)	420 (16.5)
	Depth	381 (15)	381 (15)	386 (15.2)	406 (16)
Maximum weight [kg (lb)]		116 (256)	129 (284)	200 (441)	225 (496)

Table 8.11 Mechanical Dimensions, Enclosure Sizes D5h-D8h

9 Appendix

9.1 Symbols, Abbreviations, and Conventions

°C	Degrees Celsius
°F	Degrees Fahrenheit
AC	Alternating current
AEO	Automatic energy optimization
AWG	American wire gauge
AMA	Automatic motor adaptation
DC	Direct current
EMC	Electro-magnetic compatibility
ETR	Electronic thermal relay
$f_{M,N}$	Nominal motor frequency
FC	Frequency converter
I_{INV}	Rated inverter output current
I_{LIM}	Current limit
$I_{M,N}$	Nominal motor current
$I_{VLT,MAX}$	Maximum output current
$I_{VLT,N}$	Rated output current supplied by the frequency converter
IP	Ingress protection
LCP	Local control panel
MCT	Motion control tool
n_s	Synchronous motor speed
$P_{M,N}$	Nominal motor power
PELV	Protective extra low voltage
PCB	Printed circuit board
PM Motor	Permanent magnet motor
PWM	Pulse width modulation
RPM	Revolutions per minute
Regen	Regenerative terminals
T_{LIM}	Torque limit
$U_{M,N}$	Nominal motor voltage

Table 9.1 Symbols and Abbreviations

Conventions

Numbered lists indicate procedures. Bullet lists indicate other information.

Italicized text indicates:

- Cross-reference.
- Link.
- Parameter name.
- Parameter group name.
- Parameter option.
- Footnote.

All dimensions in drawings are in [mm] (in).

9.2 Parameter Menu Structure

0-0*	Operation / Display	Motor Construction	1-10	1-82	Min Speed for Function at Stop [Hz]	4-17	Torque Limit Generator Mode	5-56	Term. 33 High Frequency
0-0*	Basic Settings	VVC+ PM/SYN RM	1-11	1-86	Compressor Min. Speed for Trip [RPM]	4-18	Current Limit	5-57	Term. 33 Low Ref./Feedb. Value
0-01	Language	Damping Gain	1-14	1-87	Compressor Min. Speed for Trip [Hz]	4-19	Max Output Frequency	5-58	Term. 33 High Ref./Feedb. Value
0-02	Motor Speed Unit	Low Speed Filter Time Const.	1-15	1-9*	Motor Temperature	4-5*	Adj. Warnings	5-59	Pulse Filter Time Constant #33
0-03	Regional Settings	High Speed Filter Time Const.	1-16	1-90	Motor Thermal Protection	4-50	Warning Current Low	5-6*	Pulse Output
0-04	Operating State at Power-up	Voltage filter time const.	1-17	1-91	Motor External Fan	4-51	Warning Current High	5-60	Terminal 27 Pulse Output Variable
0-05	Local Mode Unit	Motor Data	1-2*	1-93	Thermistor Source	4-52	Warning Speed Low	5-61	Pulse Output Max Freq #27
0-1*	Set-up Operations	Motor Power [kW]	1-20	2-*	Brakes	4-53	Warning Speed High	5-62	Terminal 29 Pulse Output Variable
0-10	Active Set-up	Motor Power [HP]	1-21	2-0*	DC-Brake	4-54	Warning Reference Low	5-63	Pulse Output Max Freq #29
0-11	Programming Set-up	Motor Voltage	1-22	2-00	DC Hold/Preheat Current	4-55	Warning Reference High	5-64	Terminal X30/6 Pulse Output Variable
0-12	This Set-up Linked to	Motor Frequency	1-23	2-01	DC Brake Current	4-56	Warning Feedback Low	5-65	Pulse Output Max Freq #X30/6
0-13	Readout: Linked Set-ups	Motor Current	1-24	2-02	DC Braking Time	4-57	Warning Feedback High	5-8*	I/O Options
0-14	Readout: Prog. Set-ups / Channel	Motor Nominal Speed	1-25	2-03	DC Brake Cut In Speed [RPM]	4-58	Missing Motor Phase Function	5-80	AHF Cap Reconnect Delay
0-2*	LCP Display	Motor Cont. Rated Torque	1-26	2-04	DC Brake Cut In Speed [Hz]	4-59	Motor Check At Start	5-9*	Bus Controlled
0-20	Display Line 1.1 Small	Motor Rotation Check	1-28	2-06	Parking Current	4-6*	Speed Bypass	5-90	Digital & Relay Bus Control
0-21	Display Line 1.2 Small	Automatic Motor Adaptation (AMA)	1-29	2-07	Parking Time	4-60	Bypass Speed From [RPM]	5-93	Pulse Out #27 Bus Control
0-22	Display Line 1.3 Small	Adv. Motor Data	1-3*	2-1*	Brake Energy Funct.	4-61	Bypass Speed From [Hz]	5-94	Pulse Out #27 Timeout Preset
0-23	Display Line 2 Large	Stator Resistance (Rs)	1-30	2-10	Brake Function	4-62	Bypass Speed To [RPM]	5-95	Pulse Out #29 Bus Control
0-24	Display Line 3 Large	Rotor Resistance (Rr)	1-31	2-16	AC brake Max. Current	4-63	Bypass Speed To [Hz]	5-96	Pulse Out #29 Timeout Preset
0-25	My Personal Menu	Main Reactance (Xh)	1-35	2-17	Over-voltage Control	4-64	Semi-Auto Bypass Set-up	5-97	Pulse Out #X30/6 Bus Control
0-3*	LCP Custom Readout	Iron Loss Resistance (Re)	1-36	3-*	Reference / Ramps	5-*	Digital In/Out	5-98	Pulse Out #X30/6 Timeout Preset
0-30	Custom Readout Unit	d-axis Inductance (Ld)	1-37	3-0*	Reference Limits	5-0*	Digital I/O mode	6-*	Analog In/Out
0-31	Custom Readout Min Value	q-axis Inductance (Lq)	1-38	3-02	Minimum Reference	5-00	Digital I/O Mode	6-0*	Live Zero Timeout Time
0-32	Custom Readout Max Value	Motor Poles	1-39	3-03	Maximum Reference	5-01	Terminal 27 Mode	6-00	Live Zero Timeout Function
0-37	Display Text 1	Back EMF at 1000 RPM	1-40	3-04	Reference Function	5-02	Terminal 29 Mode	6-01	Live Zero Timeout Function
0-38	Display Text 2	Motor Angle Offset	1-41	3-1*	References	5-1*	Digital Inputs	6-1*	Analog Input 53
0-39	Display Text 3	d-axis Inductance Sat. (LdSat)	1-44	3-10	Preset Reference	5-10	Terminal 18 Digital Input	6-10	Terminal 53 Low Voltage
0-4*	LCP Keypad	q-axis Inductance Sat. (LqSat)	1-45	3-11	Jog Speed [Hz]	5-11	Terminal 19 Digital Input	6-11	Terminal 53 High Voltage
0-40	[Hand on] Key on LCP	Position Detection Gain	1-46	3-13	Reference Site	5-12	Terminal 27 Digital Input	6-12	Terminal 53 Low Current
0-41	[Off] Key on LCP	Torque Calibration	1-47	3-14	Preset Relative Reference	5-13	Terminal 29 Digital Input	6-13	Terminal 53 High Current
0-42	[Auto on] Key on LCP	Inductance Sat. Point	1-48	3-15	Reference 1 Source	5-14	Terminal 32 Digital Input	6-14	Terminal 53 Low Ref./Feedb. Value
0-43	[Reset] Key on LCP	Load Indep. Setting	1-5*	3-16	Reference 2 Source	5-15	Terminal 33 Digital Input	6-15	Terminal 53 High Ref./Feedb. Value
0-5*	Copy/Save	Motor Magnetisation at Zero Speed	1-50	3-17	Reference 3 Source	5-16	Terminal X30/2 Digital Input	6-16	Terminal 53 Filter Time Constant
0-50	LCP Copy	Min Speed Normal Magnetising [RPM]	1-51	3-19	Jog Speed [RPM]	5-17	Terminal X30/3 Digital Input	6-17	Terminal 53 Live Zero
0-51	Set-up Copy	Min Speed Normal Magnetising [Hz]	1-52	3-4*	Ramp 1	5-18	Terminal X30/4 Digital Input	6-2*	Analog Input 54
0-6*	Password	Flying Start Test Pulses Current	1-58	3-41	Ramp 1 Ramp Up Time	5-19	Terminal 37 Safe Stop	6-20	Terminal 54 Low Voltage
0-60	Main Menu Password	Flying Start Test Pulses Frequency	1-59	3-42	Ramp 1 Ramp Down Time	5-20	Terminal X46/1 Digital Input	6-21	Terminal 54 High Voltage
0-61	Access to Main Menu w/o Password	Load Depen. Setting	1-6*	3-5*	Ramp 2	5-21	Terminal X46/3 Digital Input	6-22	Terminal 54 Low Current
0-65	Personal Menu Password	Low Speed Load Compensation	1-60	3-51	Ramp 2 Ramp Up Time	5-22	Terminal X46/5 Digital Input	6-23	Terminal 54 High Current
0-66	Access to Personal Menu w/o Password	High Speed Load Compensation	1-61	3-52	Ramp 2 Ramp Down Time	5-23	Terminal X46/7 Digital Input	6-24	Terminal 54 Low Ref./Feedb. Value
0-67	Bus Password Access	Slip Compensation	1-62	3-8*	Other Ramps	5-24	Terminal X46/9 Digital Input	6-25	Terminal 54 High Ref./Feedb. Value
0-7*	Clock Settings	Slip Compensation Time Constant	1-63	3-80	Jog Ramp Time	5-25	Terminal X46/11 Digital Input	6-26	Terminal 54 Filter Time Constant
0-70	Set Date and Time	Resonance Dampening	1-64	3-81	Quick Stop Ramp Time	5-26	Terminal X46/13 Digital Input	6-27	Terminal 54 Live Zero
0-71	Date Format	Resonance Dampening Time Constant	1-65	3-82	Starting Ramp Up Time	5-3*	Digital Outputs	6-3*	Analog Input X30/11
0-72	Time Format	Min. Current at Low Speed	1-66	3-9*	Digital Pot./Meter	5-30	Terminal 27 Digital Output	6-30	Terminal X30/11 Low Voltage
0-74	DST/Summertime	Start Adjustments	1-7*	3-90	Step Size	5-31	Terminal 29 Digital Output	6-31	Terminal X30/11 High Voltage
0-76	DST/Summertime Start	PM Start Mode	1-70	3-91	Ramp Time	5-32	Term X30/6 Digi Out (MCB 101)	6-34	Term. X30/11 Low Ref./Feedb. Value
0-77	DST/Summertime End	Start Delay	1-71	3-92	Power Restore	5-33	Term X30/7 Digi Out (MCB 101)	6-35	Term. X30/11 High Ref./Feedb. Value
0-79	Clock Fault	Start Function	1-72	3-93	Maximum Limit	5-4*	Relays	6-36	Term. X30/11 Filter Time Constant
0-81	Working Days	Flying Start	1-73	3-94	Minimum Limit	5-40	Function Relay	6-37	Term. X30/11 Live Zero
0-82	Additional Working Days	Start Speed [RPM]	1-74	3-95	Ramp Delay	5-41	On Delay, Relay	6-4*	Analog Input X30/12
0-83	Additional Non-Working Days	Start Speed [Hz]	1-75	4-*	Limits / Warnings	5-42	Off Delay, Relay	6-40	Terminal X30/12 Low Voltage
0-89	Date and Time Readout	Start Current	1-76	4-1*	Motor Limits	5-5*	Pulse Input	6-41	Terminal X30/12 High Voltage
1-*	Load and Motor	Compressor Start Max Speed [RPM]	1-77	4-10	Motor Speed Direction	5-50	Term. 29 Low Frequency	6-44	Term. X30/12 Low Ref./Feedb. Value
1-0*	General Settings	Compressor Start Max Speed [Hz]	1-78	4-11	Motor Speed Low Limit [RPM]	5-51	Term. 29 High Frequency	6-45	Term. X30/12 High Ref./Feedb. Value
1-00	Configuration Mode	Compressor Start Max Time to Trip	1-79	4-12	Motor Speed Low Limit [Hz]	5-52	Term. 29 Low Ref./Feedb. Value	6-46	Term. X30/12 Filter Time Constant
1-03	Torque Characteristics	Stop Adjustments	1-8*	4-13	Motor Speed High Limit [RPM]	5-53	Term. 29 High Ref./Feedb. Value	6-47	Term. X30/12 Live Zero
1-06	Clockwise Direction	Function at Stop	1-80	4-14	Motor Speed High Limit [Hz]	5-54	Pulse Filter Time Constant #29	6-5*	Analog Output 42
1-1*	Motor Selection	Min Speed for Function at Stop [RPM]	1-81	4-16	Torque Limit Motor Mode	5-55	Term. 33 Low Frequency	6-50	Terminal 42 Output



6-51	Terminal 42 Output Min Scale	8-81	Bus Error Count	12-04	DHCP Server	14-01	Switching Frequency	15-20	Historic Log: Event
6-52	Terminal 42 Output Max Scale	8-82	Slave Message Count	12-05	Lease Expires	14-03	Overmodulation	15-21	Historic Log: Value
6-53	Terminal 42 Output Bus Control	8-83	Slave Error Count	12-06	Name Servers	14-04	PWM Random	15-22	Historic Log: Time
6-54	Terminal 42 Output Timeout Preset	8-9*	Bus Jog / Feedback	12-07	Domain Name	14-1*	Mains On/Off	15-23	Historic Log: Date and Time
6-60	Terminal X30/8 Output	8-90	Bus Jog 1 Speed	12-08	Host Name	14-10	Mains Failure	15-3*	Alarm Log
6-61	Terminal X30/8 Min. Scale	8-91	Bus Jog 2 Speed	12-09	Physical Address	14-11	Mains Voltage at Mains Fault	15-30	Alarm Log: Error Code
6-62	Terminal X30/8 Max. Scale	8-94	Bus Feedback 1	12-1*	Ethernet Link Parameters	14-12	Function at Mains Imbalance	15-31	Alarm Log: Value
6-63	Terminal X30/8 Output Bus Control	8-95	Bus Feedback 2	12-10	Link Status	14-16	Kin. Backup Gain	15-32	Alarm Log: Time
6-64	Terminal X30/8 Output Timeout Preset	8-96	Bus Feedback 3	12-11	Link Duration	14-2*	Reset Functions	15-33	Alarm Log: Date and Time
6-7*	Terminal Output X45/1	9-3**	PROFeedback	12-12	Auto Negotiation	14-20	Reset Mode	15-34	Alarm Log: Status
6-70	Terminal X45/1 Output	9-00	Setpoint	12-13	Link Speed	14-21	Automatic Restart Time	15-35	Alarm Log: Alarm Text
6-71	Terminal X45/1 Min. Scale	9-07	Actual Value	12-14	Link Duplex	14-22	Operation Mode	15-4*	Drive Identification
6-72	Terminal X45/1 Max. Scale	9-15	PCD Write Configuration	12-18*	Other Ethernet Services	14-23	Typecode Setting	15-40	FC Type
6-73	Terminal X45/1 Bus Control	9-16	PCD Read Configuration	12-80	FTP Server	14-25	Trip Delay at Torque Limit	15-41	Power Section
6-74	Terminal Output X45/3	9-18	Node Address	12-81	HTTP Server	14-26	Trip Delay at Inverter Fault	15-42	Voltage
6-8*	Terminal X45/1 Output Timeout Preset	9-23	Telegram Selection	12-82	SMTP Service	14-28	Production Settings	15-43	Software Version
6-80	Terminal X45/3 Output	9-27	Parameter Edit	12-9*	Advanced Ethernet Services	14-29	Service Code	15-44	Ordered Typecode String
6-81	Terminal X45/3 Min. Scale	9-28	Process Control	12-90	Cable Diagnostic	14-30	Current Limit Ctrl.	15-45	Actual Typecode String
6-82	Terminal X45/3 Max. Scale	9-44	Fault Message Counter	12-91	Auto Cross Over	14-31	Current Lim Ctrl, Proportional Gain	15-46	Frequency Converter Ordering No
6-83	Terminal X45/3 Bus Control	9-45	Fault Code	12-92	IGMP Snooping	14-3*	Energy Optimising	15-47	Power Card Ordering No
6-84	Terminal X45/3 Output Timeout Preset	9-47	Fault Number	12-93	Cable Error Length	14-40	VT Level	15-48	LCP Id No
8-0*	General Settings	9-52	Fault Situation Counter	12-94	Broadcast Storm Protection	14-41	AEQ Minimum Magnetisation	15-49	SW ID Control Card
8-01	Control Site	9-53	Profibus Warning Word	12-95	Broadcast Storm Filter	14-42	Minimum AEO Frequency	15-50	SW ID Power Card
8-02	Control Source	9-64	Device Identification	12-96	Port Config	14-43	Motor Cosphi	15-51	Frequency Converter Serial Number
8-03	Control Timeout Time	9-65	Profile Number	12-98	Interface Counters	14-45*	Environment	15-53	Power Card Serial Number
8-04	Control Timeout Function	9-67	Control Word 1	12-99	Media Counters	14-50	RFI Filter	15-60	Option Mounted
8-05	End-of-Timeout Function	9-68	Status Word 1	13-0*	Smart Logic	14-51	DC Link Compensation	15-61	Option SW Version
8-06	Reset Control Timeout	9-70	Programming Set-up	13-00	SL Controller Mode	14-52	Fan Control	15-62	Option Ordering No
8-1*	Diagnosis Trigger	9-71	Profibus Save Data Values	13-01	Start Event	14-53	Fan Monitor	15-63	Option Serial No
8-10	Control Profile	9-72	ProfibusDriveReset	13-02	Stop Event	14-55	Output Filter	15-70	Option in Slot A
8-13	Configurable Status Word STW	9-75	DO Identification	13-03	Reset SLC	14-6*	Auto Derate	15-71	Slot A Option SW Version
8-16	Store Data Values	9-80	Defined Parameters (1)	13-10	Comparators	14-60	Function at Over Temperature	15-72	Option in Slot B
8-3*	FC Port Settings	9-81	Defined Parameters (2)	13-11	Comparator Operand	14-61	Function at Inverter Overload	15-73	Slot B Option SW Version
8-30	Address	9-82	Defined Parameters (3)	13-12	Comparator Operator	14-62	Inv. Overload Derate Current	15-74	Option in Slot C0/E0
8-32	Baud Rate	9-84	Defined Parameters (4)	13-2*	Timers	14-8*	Options	15-75	Slot C0/E0 Option SW Version
8-33	Parity / Stop Bits	9-85	Defined Parameters (5)	13-20	SL Controller Timer	14-80	Option Supplied by External 24VDC	15-76	Option in Slot C1/E1
8-35	Minimum Response Delay	9-90	Changed Parameters (1)	13-40	Logic Rules	14-89	Option Detection	15-8*	Operating Data II
8-36	Maximum Response Delay	9-91	Changed Parameters (2)	13-41	Logic Rule Boolean 1	14-9*	Fault Settings	15-80	Fan Running Hours
8-37	Maximum Inter-Char Delay	9-92	Changed Parameters (3)	13-42	Logic Rule Boolean 2	14-90	Fault Level	15-81	Preset Fan Running Hours
8-4*	Adv. Protocol Set.	9-93	Changed Parameters (4)	13-43	Logic Rule Boolean 3	15-0*	Operating Data	15-9*	Parameter Info
8-40	Telegram Selection	9-94	Changed Parameters (5)	13-44	Logic Rule Boolean 3	15-00	Operating hours	15-92	Defined Parameters
8-42	PCD Write Configuration	11-1**	LonWorks	13-5*	States	15-01	Running hours	15-99	Modified Parameters
8-43	PCD Read Configuration	11-2*	Lon Param. Access	13-51	SL Controller Event	15-02	kWh Counter	16-0*	Data Readouts
8-45	BTM Transaction Command	11-21	Store Data Values	13-52	SL Controller Action	15-03	Power Up's	16-00	General Status
8-46	BTM Transaction Status	11-9*	AK LonWorks	13-9*	User Defined Alerts	15-04	Control Word	16-00	Control Word
8-47	BTM Timeout	11-90	VLT Network Address	13-90	Alert Trigger	15-05	Over Temp's	16-01	Reference [Unit]
8-50	Coasting Select	11-91	AK Service Pin	13-91	Alert Action	15-06	Reset kWh Counter	16-02	Reference [%]
8-52	DC Brake Select	11-98	Alarm Text	13-92	Alert Text	15-07	Reset Running Hours Counter	16-03	Status Word
8-53	Start Select	11-99	Alarm Status	13-9*	User Defined Readouts	15-08	Number of Starts	16-05	Main Actual Value [%]
8-54	Reversing Select	12-0*	IP Settings	13-97	Alert Alarm Word	15-1*	Data Log Settings	16-09	Custom Readout
8-55	Set-up Select	12-00	IP Address Assignment	13-98	Alert Warning Word	15-10	Logging Source	16-1*	Motor Status
8-56	Preset Reference Select	12-01	IP Address	13-99	Alert Status Word	15-11	Logging Interval	16-10	Power [kW]
8-8*	FC Port Diagnostics	12-02	Subnet Mask	14-0*	Special Functions	15-12	Trigger Event	16-11	Power [hpl]
8-80	Bus Message Count	12-03	Default Gateway	14-00	Inverter Switching	15-13	Logging Mode	16-12	Motor Voltage
						15-14	Samples Before Trigger	16-13	Frequency
						15-2*	Historic Log	16-14	Motor current

16-15	Frequency [%]	16-95	Ext. Status Word 2	20-8*	PID Basic Settings	21-55	Ext. 3 Setpoint	22-75	Short Cycle Protection
16-16	Torque [Nm]	16-96	Maintenance Word	20-81	PID Normal/ Inverse Control	21-56	Ext. 3 PID Conversion	22-76	Interval between Starts
16-17	Speed [RPM]	16-99	Ext. Status Word 3	20-82	PID Start Speed [RPM]	21-57	Ext. 3 Reference [Unit]	22-77	Minimum Run Time
16-18	Motor Thermal	18-0*	Info & Readouts	20-83	PID Start Speed [Hz]	21-58	Ext. 3 Feedback [Unit]	22-78	Minimum Run Time Override
16-22	Torque [%]	18-0*	Maintenance Log	20-84	On Reference Bandwidth	21-59	Ext. 3 Output [%]	22-79	Minimum Run Time Override Value
16-24	Calibrated Stator Resistance	18-00	Maintenance Log: Item	20-9*	PID Controller	21-6*	Ext. CL 3 PID	22-8*	Flow Compensation
16-3*	Drive Status	18-01	Maintenance Log: Action	20-91	PID Anti Windup	21-60	Ext. 3 Normal/Inverse Control	22-80	Flow Compensation
16-30	DC Link Voltage	18-02	Maintenance Log: Time	20-93	PID Proportional Gain	21-61	Ext. 3 Proportional Gain	22-81	Square-linear Curve Approximation
16-31	System Temp.	18-03	Maintenance Log: Date and Time	20-94	PID Integral Time	21-62	Ext. 3 Integral Time	22-82	Work Point Calculation
16-32	Brake Energy /s	18-3*	Inputs & Outputs	20-95	PID Differentiation Time	21-63	Ext. 3 Differentiation Time	22-83	Speed at No-Flow [RPM]
16-33	Brake Energy /2 min	18-30	Analog Input X42/1	20-96	PID Diff. Gain Limit	21-64	Ext. 3 Dif. Gain Limit	22-84	Speed at No-Flow [Hz]
16-34	Heatsink Temp.	18-31	Analog Input X42/3	21-1*	Ext. Closed Loop	21-7*	Ext. Feeds. Adv. Conversion	22-85	Speed at Design Point [RPM]
16-35	Inverter Thermal	18-32	Analog Input X42/5	21-0*	Ext. CL Autotuning	21-70	Refrigerant	22-86	Speed at Design Point [Hz]
16-36	Inv. Nom. Current	18-33	Analog Out X42/7 [V]	21-00	Closed Loop Type	21-71	User Defined Refrigerant A1	22-87	Pressure at No-Flow Speed
16-37	Inv. Max. Current	18-34	Analog Out X42/9 [V]	21-01	PID Performance	21-72	User Defined Refrigerant A2	22-88	Pressure at Rated Speed
16-38	SL Controller State	18-35	Analog Out X42/11 [V]	21-02	PID Output Change	21-73	User Defined Refrigerant A3	22-89	Flow at Design Point
16-39	Control Card Temp.	18-5*	Ref. & Feeds.	21-03	Minimum Feedback Level	22-1*	Appl. Functions	22-90	Flow at Rated Speed
16-40	Logging Buffer Full	18-57	Air Pressure to Flow Air Flow	21-04	Maximum Feedback Level	22-0*	Miscellaneous	23-1*	Time-based Functions
16-41	LCP Bottom Statusline	18-6*	Inputs & Outputs 2	21-09	PID Autotuning	22-00	External Interlock Delay	23-0*	Timed Actions
16-49	Current Fault Source	18-60	Digital Input 2	21-1*	Ext. CL 1 Ref./Fb.	22-1*	Air Pres. to Flow	23-00	ON Time
16-5*	Ref. & Feeds.	18-7*	Rectifier Status	21-10	Ext. 1 Ref./Feedback Unit	22-10	Air Pressure to Flow Signal source	23-01	ON Action
16-50	External Reference	18-70	Mains Voltage	21-11	Ext. 1 Minimum Reference	22-11	Air Pressure to Flow Fan k-factor	23-02	OFF Time
16-52	Feedback[Unit]	18-71	Mains Frequency	21-12	Ext. 1 Maximum Reference	22-12	Air Pressure to Flow Air density	23-03	OFF Action
16-53	Digi Pot Reference	18-72	Mains Imbalance	21-13	Ext. 1 Reference Source	22-13	Air Pressure to Flow Fan flow unit	23-04	Occurrence
16-54	Feedback 1 [Unit]	18-75	Rectifier DC Volt.	21-14	Ext. 1 Feedback Source	22-2*	No-Flow Detection	23-1*	Maintenance
16-55	Feedback 2 [Unit]	20-0*	Drive Closed Loop	21-15	Ext. 1 Setpoint	22-20	Low Power Auto Set-up	23-10	Maintenance Item
16-56	Feedback 3 [Unit]	20-0*	Feedback	21-16	Ext. 1 PID Conversion	22-21	Low Power Detection	23-11	Maintenance Action
16-6*	Inputs & Outputs	20-00	Feedback 1 Source	21-17	Ext. 1 Reference [Unit]	22-22	Low Speed Detection	23-12	Maintenance Time Base
16-60	Digital Input	20-01	Feedback 1 Conversion	21-18	Ext. 1 Feedback [Unit]	22-23	No-Flow Function	23-13	Maintenance Time Interval
16-61	Terminal 53 Switch Setting	20-02	Feedback 1 Source Unit	21-19	Ext. 1 Output [%]	22-24	No-Flow Delay	23-14	Maintenance Date and Time
16-62	Analog Input 53	20-03	Feedback 2 Source	21-2*	Ext. CL 1 PID	22-26	Dry Pump Function	23-1*	Maintenance Reset
16-63	Terminal 54 Switch Setting	20-04	Feedback 2 Conversion	21-20	Ext. 1 Normal/Inverse Control	22-27	Dry Pump Delay	23-15	Reset Maintenance Word
16-64	Analog Input 54	20-05	Feedback 2 Source Unit	21-21	Ext. 1 Proportional Gain	22-3*	No-Flow Power Tuning	23-16	Maintenance Text
16-65	Analog Output 42 [mA]	20-06	Feedback 3 Source	21-22	Ext. 1 Integral Time	22-30	No-Flow Power	23-5*	Energy Log
16-66	Digital Output [bin]	20-07	Feedback 3 Conversion	21-23	Ext. 1 Differentiation Time	22-31	Power Correction Factor	23-50	Energy Log Resolution
16-67	Pulse Input #29 [Hz]	20-08	Feedback 3 Source Unit	21-24	Ext. 1 Dif. Gain Limit	22-32	Low Speed [RPM]	23-51	Period Start
16-68	Pulse Input #33 [Hz]	20-1*	Reference/Setpoint	21-3*	Ext. CL 2 Ref./Fb.	22-33	Low Speed [Hz]	23-53	Energy Log
16-69	Pulse Output #27 [Hz]	20-12	Feedback/Setpoint	21-30	Ext. 2 Ref./Feedback Unit	22-34	Low Speed Power [kW]	23-54	Reset Energy Log
16-70	Pulse Output #29 [Hz]	20-20	Feedback Function	21-31	Ext. 2 Minimum Reference	22-35	Low Speed Power [HP]	23-6*	Trending
16-71	Relay Output [bin]	20-21	Setpoint 1	21-32	Ext. 2 Maximum Reference	22-36	High Speed [RPM]	23-60	Trend Variable
16-72	Counter A	20-22	Setpoint 2	21-33	Ext. 2 Reference Source	22-37	High Speed [Hz]	23-61	Continuous Bin Data
16-73	Counter B	20-23	Setpoint 3	21-34	Ext. 2 Feedback Source	22-38	High Speed Power [kW]	23-62	Timed Bin Data
16-75	Analog In X30/11	20-25	Setpoint Type	21-35	Ext. 2 Setpoint	22-39	High Speed Power [HP]	23-63	Timed Period Start
16-76	Analog In X30/12	20-3*	Feedback Adv. Conv	21-36	Ext. 2 PID Conversion	22-4*	Sleep Mode	23-64	Timed Period Stop
16-77	Analog Out X30/8 [mA]	20-30	Refrigerant	21-37	Ext. 2 Reference [Unit]	22-40	Minimum Run Time	23-65	Minimum Bin Value
16-78	Analog Out X45/1 [mA]	20-31	User Defined Refrigerant A1	21-38	Ext. 2 Feedback [Unit]	22-41	Minimum Sleep Time	23-66	Reset Continuous Bin Data
16-79	Analog Out X45/3 [mA]	20-32	User Defined Refrigerant A2	21-39	Ext. 2 Output [%]	22-42	Wake-up Speed [RPM]	23-67	Reset Timed Bin Data
16-8*	Fieldbus & FC Port	20-33	User Defined Refrigerant A3	21-4*	Ext. CL 2 PID	22-43	Wake-up Speed [Hz]	23-8*	Payback Counter
16-80	Fieldbus CTW 1	20-4*	Thermostat/Pressostat	21-40	Ext. 2 Normal/Inverse Control	22-44	Wake-up Ref./FB Difference	23-80	Power Reference Factor
16-82	Fieldbus REF 1	20-40	Thermostat/Pressostat Function	21-41	Ext. 2 Proportional Gain	22-45	Setpoint Boost	23-81	Energy Cost
16-84	Comm. Option STW	20-41	Cut-out Value	21-42	Ext. 2 Integral Time	22-46	Maximum Boost Time	23-82	Investment
16-85	FC Port CTW 1	20-42	Cut-in Value	21-43	Ext. 2 Differentiation Time	22-5*	End of Curve	23-83	Energy Savings
16-86	FC Port REF 1	20-7*	PID Autotuning	21-44	Ext. 2 Dif. Gain Limit	22-50	End of Curve Function	23-84	Cost Savings
16-9*	Diagnosis Readouts	20-70	Closed Loop Type	21-5*	Ext. CL 3 Ref./Fb.	22-51	End of Curve Delay	24-1*	Appl. Functions 2
16-90	Alarm Word	20-71	PID Performance	21-50	Ext. 3 Ref./Feedback Unit	22-6*	Broken Belt Detection	24-9*	Multi-Motor Funct.
16-91	Alarm Word 2	20-72	PID Output Change	21-51	Ext. 3 Minimum Reference	22-60	Broken Belt Function	24-90	Missing Motor Function
16-92	Warning Word	20-73	Minimum Feedback Level	21-52	Ext. 3 Maximum Reference	22-61	Broken Belt Torque	24-91	Missing Motor Coefficient 1
16-93	Warning Word 2	20-74	Maximum Feedback Level	21-53	Ext. 3 Reference Source	22-62	Broken Belt Delay	24-92	Missing Motor Coefficient 2
16-94	Ext. Status Word	20-79	PID Autotuning	21-54	Ext. 3 Feedback Source	22-7*	Short Cycle Protection	24-93	Missing Motor Coefficient 3



24-94	Missing Motor Coefficient 4	28-24	Warning Level	43-1*	Power Card Status
24-95	Locked Rotor Function	28-25	Warning Action	43-10	HS Temp. ph.U
24-96	Locked Rotor Coefficient 1	28-26	Emergency Level	43-11	HS Temp. ph.V
24-97	Locked Rotor Coefficient 2	28-27	Discharge Temperature	43-12	HS Temp. ph.W
24-98	Locked Rotor Coefficient 3	28-7*	Day/Night Settings	43-13	PC Fan A Speed
24-99	Locked Rotor Coefficient 4	28-71	Day/Night Bus Indicator	43-14	PC Fan B Speed
25-0*	Pack Controller	28-72	Enable Day/Night Via Bus	43-15	PC Fan C Speed
25-0*	System Settings	28-73	Night Setback	43-2*	Fan Pow/Card Status
25-00	Pack Controller	28-74	Night Speed Drop [RPM]	43-20	FPC Fan A Speed
25-02	Motor Start	28-75	Night Speed Drop Override	43-21	FPC Fan B Speed
25-04	Pump Cycling	28-76	Night Speed Drop [Hz]	43-22	FPC Fan C Speed
25-05	Fixed Lead Compressor	28-8*	PO Optimization	43-23	FPC Fan D Speed
25-06	Number of Compressors	28-81	dPO Offset	43-24	FPC Fan E Speed
25-20	Neutral Zone [unit]	28-82	PO	43-25	FPC Fan F Speed
25-21	+ Zone [unit]	28-83	PO Setpoint		
25-22	- Zone [unit]	28-84	PO Reference		
25-23	Fixed speed neutral Zone [unit]	28-85	PO Minimum Reference		
25-24	+ Zone Delay	28-86	PO Maximum Reference		
25-25	- Zone Delay	28-9*	Injection Control		
25-26	++ Zone Delay	28-90	Injection On		
25-27	-- Zone Delay	28-91	Delayed Compressor Start		
25-28	Override Bandwidth Ramp Time	29-*	Compressor Functions 2		
25-3*	Staging Functions	29-4*	Pre/Post Lube		
25-30	Destage At No-Flow	29-40	Pre/Post Lube Function		
25-31	Stage Function	29-41	Pre Lube Time		
25-32	Stage Function Time	29-42	Post Lube Time		
25-33	Destage Function	30-2*	Special Features		
25-34	Destage Function Time	30-2*	Adv. Start Adjust		
25-4*	Staging Settings	30-22	Locked Rotor Protection		
25-42	Staging Threshold	30-23	Locked Rotor Detection Time [s]		
25-43	Destaging Threshold	30-3*	High/Low Pres. Stop 1		
25-44	Staging Speed [RPM]	30-30	Pressure Transmitter		
25-45	Staging Speed [Hz]	30-31	Pressure Conversion		
25-46	Destaging Speed [RPM]	30-32	Pressure Source Unit		
25-47	Destaging Speed [Hz]	30-33	Temperature Unit		
25-5*	Alternation Settings	30-34	High Pres. Stop		
25-50	Lead Pump Alternation	30-35	High Pres. Start		
25-51	Alternation Event	30-36	Low Pres. Stop		
25-52	Alternation Time Interval	30-37	Low Pres. Start		
25-53	Alternation Timer Value	30-38	Pressure 1		
25-54	Alternation Predefined Time	30-4*	High/Low Pres. Stop 2		
25-55	Alternate if Load < 50%	30-40	Pressure Transmitter		
25-56	Staging Mode at Alternation	30-41	Pressure Conversion		
25-58	Run Next Pump Delay	30-42	Pressure Source Unit		
25-59	Run on Mains Delay	30-43	Temperature Unit		
25-8*	Status	30-44	High Pres. Stop		
25-80	Pack Status	30-45	High Pres. Start		
25-81	Compressor Status	30-46	Low Pres. Stop		
25-82	Lead Compressor	30-47	Low Pres. Start		
25-83	Relay Status	30-48	Pressure 2		
25-84	Compressor ON Time	30-4*	High/Low Pres. Ramp		
25-85	Relay ON Time	30-49	Pressure Stop Ramp Time		
25-86	Reset Relay Counters	30-5*	Unit Configuration		
25-87	Inverse Interlock	30-50	Heat Sink Fan Mode		
25-88	Pack capacity [%]	43-5*	Unit Readouts		
25-9*	Service	43-0*	Component Status		
25-90	Compressor Interlock	43-00	Component Temp.		
25-91	Manual Alternation	43-01	Auxiliary Temp.		

Index

A

Abbreviation..... 74

AC mains..... 6, 31

AC waveform..... 6

Additional resources..... 3

Alarms

 Alarm log..... 38

 Alarms..... 51

 List of..... 52

AMA

 AMA..... 49, 57

 with T27 connected..... 43

 without T27 connected..... 43

 Automatic motor adaptation (AMA)..... 43

Ambient conditions..... 65

Analog

 input..... 32

 output..... 32

 speed reference..... 43

Approvals and certifications..... 6

Auto on..... 39, 42, 49, 50

Automatic motor adaptation

 Warning..... 57

Auto-reset..... 37

Auxiliary equipment..... 36

B

Block diagram..... 6

Brake

 resistor..... 52

 Terminal torque rating..... 72

Brake resistor

 Warning..... 55

Braking..... 49

Burst transient..... 11

Bus termination switch..... 35

C

Cable routing..... 36

Cables

 Cable length and cross-section..... 66

 Specifications..... 66

Circuit breaker..... 36, 69

Clearance requirement..... 9

Closed loop..... 34

Conduct..... 36

Control

 terminal..... 51

 Signal..... 49

 Terminal..... 39, 41, 49

 Wiring..... 11, 14, 33, 36

Control card

 RS485..... 67

 Specifications..... 69

 Warning..... 57

Control input/output

 Specifications..... 66

Control wiring..... 14

Convention..... 74

Cooling..... 9

Cooling clearance..... 36

Current

 DC..... 6

 Leakage..... 11

 Limit..... 61

 Motor..... 6, 38

 RMS..... 6

D

DC current..... 6, 11, 49

Default setting..... 39

Digital input..... 34, 50

Dimensions shipping..... 72

Discharge time..... 7

Disconnect switch..... 37

Door/panel cover

 Torque rating..... 72

E

EMC..... 11

EMC interference..... 14

Energy efficiency class..... 65

Extended options cabinet..... 5

External alarm reset..... 46

External command..... 6, 51

External controller..... 3

F

Fans

 Warning..... 59

Fault log..... 38

Feedback..... 34, 36, 49

Floating delta..... 31

Fuse..... 11, 36, 55, 69

G

Gland plate
 Torque rating..... 72

Ground
 connection..... 36
 wire..... 11
 Grounding..... 14, 31, 36, 37
 Terminal torque rating..... 72
 Warning..... 56

Grounded delta..... 31

H

Hand on..... 39, 49

Harmonics..... 6

Heat sink
 Access panel torque rating..... 72
 Warning..... 56, 58

High voltage..... 7, 37

I

Initialization..... 40

Input
 AC..... 6, 31
 Analog..... 32
 Current..... 31
 Digital..... 34
 Disconnect..... 31
 Power..... 6, 11, 14, 31, 36, 37, 51
 Power wiring..... 36
 Signal..... 34
 Terminal..... 31, 34, 37
 Voltage..... 37

Installation..... 33, 36

Installation environment..... 9

Intended use..... 3

Interference isolation..... 36

Interior view..... 4

Isolated mains..... 31

J

Jumper..... 34

L

Leakage current..... 8, 11

Lifting..... 10

Load share
 Terminal torque rating..... 72

Load sharing..... 7, 72

Local control..... 37, 39, 49

Local control panel (LCP)..... 37

M

Main menu..... 38

Mains
 supply (L1, L2, L3)..... 65
 voltage..... 38, 49
 Terminal torque rating..... 72

Maintenance..... 48

Manual initialization..... 40

MCT 10..... 32, 37

Menu key..... 38

Menu structure..... 38

Motor
 Cable..... 14
 Connection..... 14
 current..... 6, 38
 data..... 61
 Output (U, V, W)..... 65
 Overheating..... 53
 Power..... 11, 38
 Protection..... 3
 Rotation check..... 41
 Speed..... 40
 Status..... 3
 Terminal torque rating..... 72
 Thermal protection..... 47
 Thermistor..... 47
 Unintended motor rotation..... 8
 Warning..... 53, 55
 Wiring..... 14, 36

Mounting..... 10, 36

N

Nameplate..... 9

Navigation key..... 38, 40, 49

O

Open loop
 Open loop..... 34
 Speed accuracy..... 68

Operation key..... 38

Optional equipment..... 34, 37

Output
 current..... 49
 power wiring..... 36
 terminal..... 37

Overcurrent protection..... 11

Overvoltage..... 50, 61

P

PELV..... 47

Phase loss..... 52

Potential equalization..... 11

Power card	
Warning.....	58
Power connection.....	11
Power factor.....	6, 36
Programming.....	34, 37, 38, 39
Pulse start/stop.....	45
Q	
Qualified personnel.....	7
Quick menu.....	38
R	
Ramp-down time.....	61
Ramp-up time.....	61
Reference.....	38, 43, 49, 50
Regeneration	
Terminal torque rating.....	72
Regeneration.....	72
Relays	
Output specifications.....	68
Remote command.....	3
Remote reference.....	50
Reset.....	37, 38, 39, 40, 51, 58
RFI filter.....	31
RMS current.....	6
RS485.....	35, 47
Run command.....	42
Run permissive.....	50
S	
Safe Torque Off	
Safe Torque Off.....	34
Warning.....	58
Safety.....	8
Serial communication	
Cover torque rating.....	72
Serial communication.....	32, 39, 50, 51
Serial communication.....	49
Service.....	48
Setpoint.....	50
Set-up.....	38, 42
Shielded cable.....	14, 36
Short circuit.....	54
Short circuit current rating (SCCR).....	71
Sleep mode.....	50
SmartStart.....	40

Speed	
Motor.....	40
reference.....	34, 42, 43, 49
reference, analog.....	43
Start/stop command.....	45
Start-up.....	40
Status display.....	49
Status mode.....	49
STO.....	34
Storage.....	9
Supply voltage.....	32, 37, 55, 67
Switch.....	34
Switches	
Bus termination.....	35
Switching frequency.....	50
Symbol.....	74
System feedback.....	3
T	
Terminal	
Control terminal.....	51
Input.....	34
Location, D1h.....	16
Location, D2h.....	16
Location, D3h.....	17
Location, D4h.....	18
53.....	34
54.....	34
Thermal protection	
Motor.....	47
Thermal protection.....	6
Thermistor	
Thermistor.....	32
control wiring.....	32
Warning.....	58
Torque	
Fastener rating.....	72
Limit.....	53
characteristic.....	65
limit.....	61
Transient protection.....	6
Trip.....	47
Trip lock.....	51
Trips.....	51
Troubleshooting	
Troubleshooting.....	61
Warnings and alarms.....	52
U	
UL certification.....	6
Unintended start.....	7, 48
USB	
Specifications.....	69

V

Voltage imbalance..... 52

W

Warnings

List of..... 52

Warnings..... 51

Weight..... 72

Windmilling..... 8

Wire size..... 11, 14

Wiring

Control..... 14, 33, 36

Motor..... 14, 36



.....
Danfoss can accept no responsibility for possible errors in catalogues, brochures and other printed material. Danfoss reserves the right to alter its products without notice. This also applies to products already on order provided that such alterations can be made without subsequential changes being necessary in specifications already agreed. All trademarks in this material are property of the respective companies. Danfoss and the Danfoss logotype are trademarks of Danfoss A/S. All rights reserved.
.....

Danfoss A/S
Ulsnaes 1
DK-6300 Graasten
vlt-drives.danfoss.com

